



DESIGN HIGHLIGHTS

- Quiet smooth action at approximately 40mm [1.6] per second
- Full cable management
- Wide range of mounting options
- 24V DC motor. Suitable for direct DC supply
- Marine suitable robust beam

OPTIONS

- Push Flap
- Electric Flap Actuator
- Custom screen back cover
- Heavy duty option
- Outdoor Option

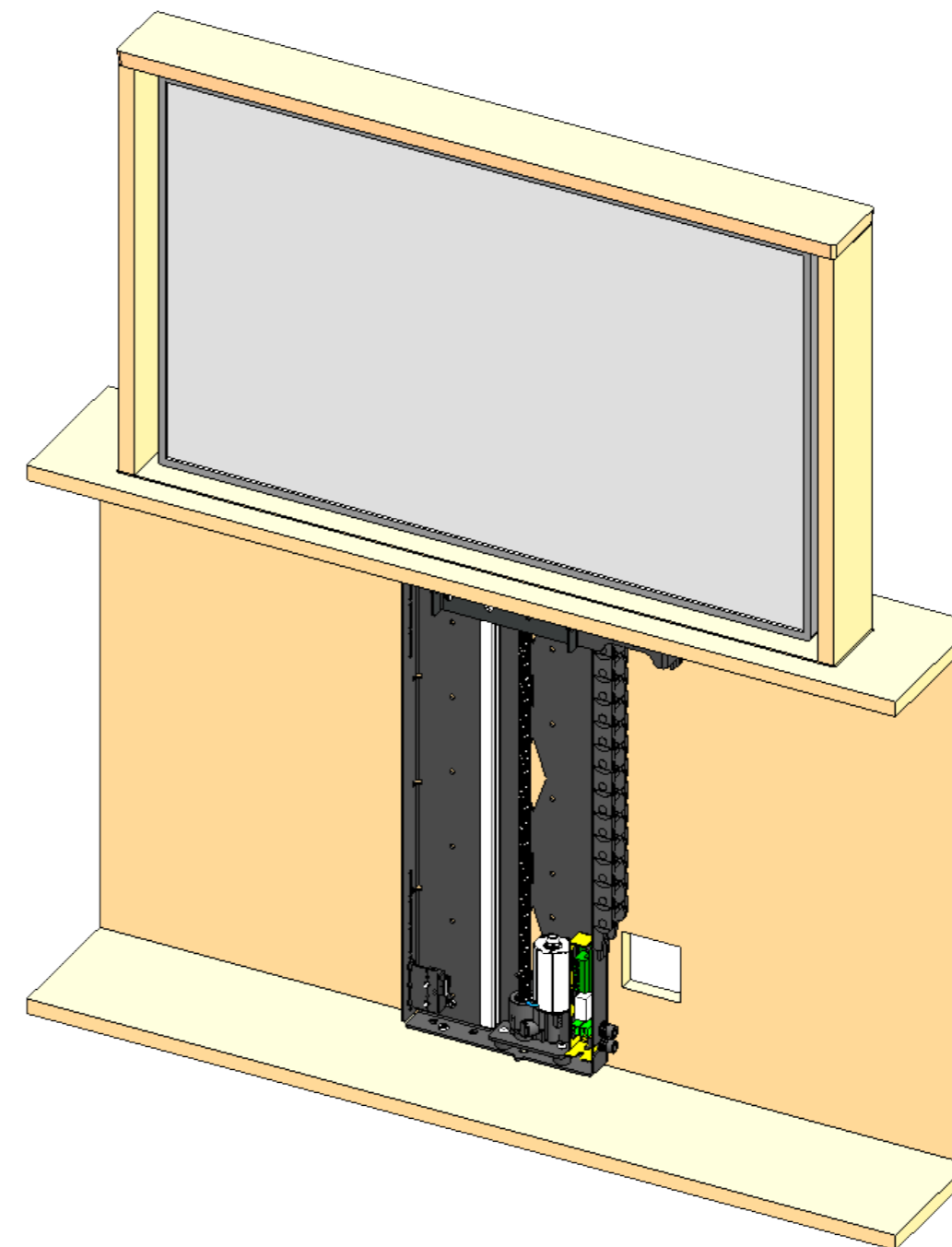
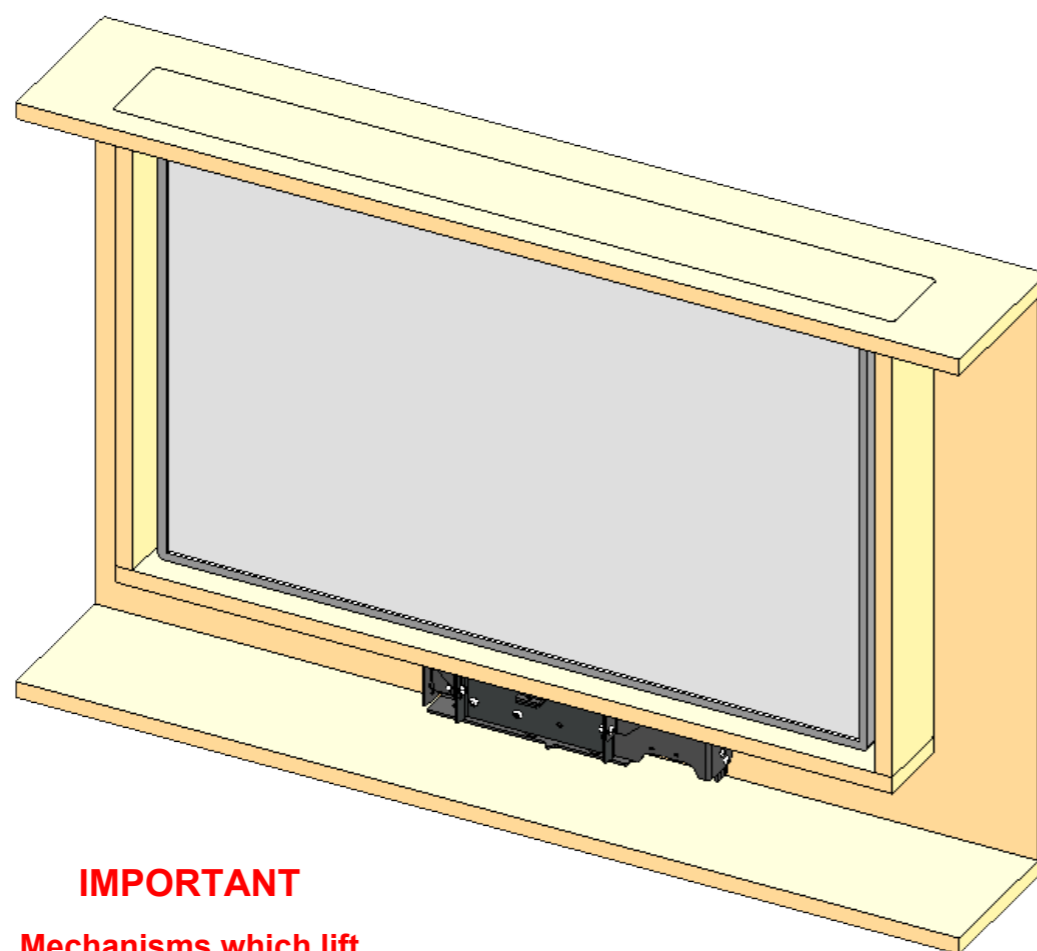

FUNCTION

An electric mechanism to lift a flat screen television. Suitable for marine use. Shown here for use with an enclosed screen

SUITABILITY

Suitable for a total lifting weight of 25Kg [55lbs] or 16Kg [35lbs] in a marine environment.

Maximum screen height 524mm [20.6]

Lift systems to suit different screen heights and weights are available

SPECIFYING

Check screen mounting details and request a suitable mount plate

CONTROL

Supplied with basic infrared remote. Can be learnt by many learning remotes.

Also has switch control and RS232 so can be operated by relays, switches, Crestron / AMX or Lutron systems.

WARNING

It is the responsibility of the installer to warn all potential end users of the dangers of interfering with mechanisms during operation

IMPORTANT

Mechanisms which lift or move weights need to be checked on a yearly basis for any damage which may result in an accident

Design Highlights

A space efficient and robust lifting mechanism, suitable for use in marine environments.

A robust 24V DC motor with a purpose made lead screw enables a quiet and smooth lifting action at approximately 40mm [1.6] per second.

A high precision linear guideway ensures stability and durability of the beam to prevent any unwanted movement of the screen.

Adjustable UP and DOWN positions allow for a precise final setup within the cabinet.

Full cable management protects all screen and power cables from damage and is easily accessible for future changes to the AV setup.

A wide range of mounting options are available to suit different screens and speaker arrangements.

The Box Enclosure gives the product a neat finish, concealing all screen connections.

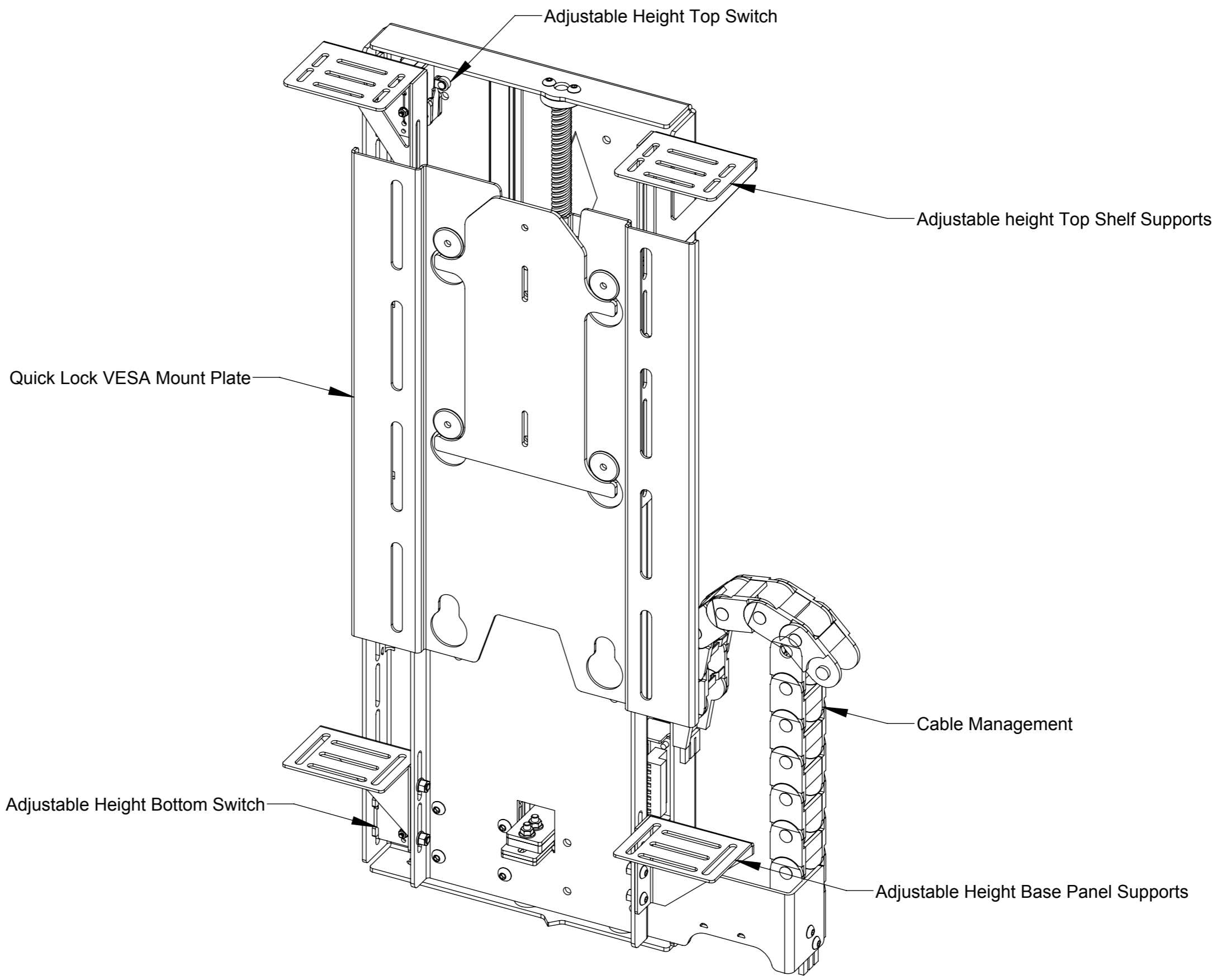

Cable Routing

Screen cables are routed behind the Base Panel and out the right side of the Beam into the Cable Track. Cables must be routed carefully to prevent any interference with the LSL beam as it operates.

Screen and Mechanism cables should be routed to a control box in the bottom of the cabinet.

- SCREEN CABLE
- MECHANISM CABLE
- POWER CABLE

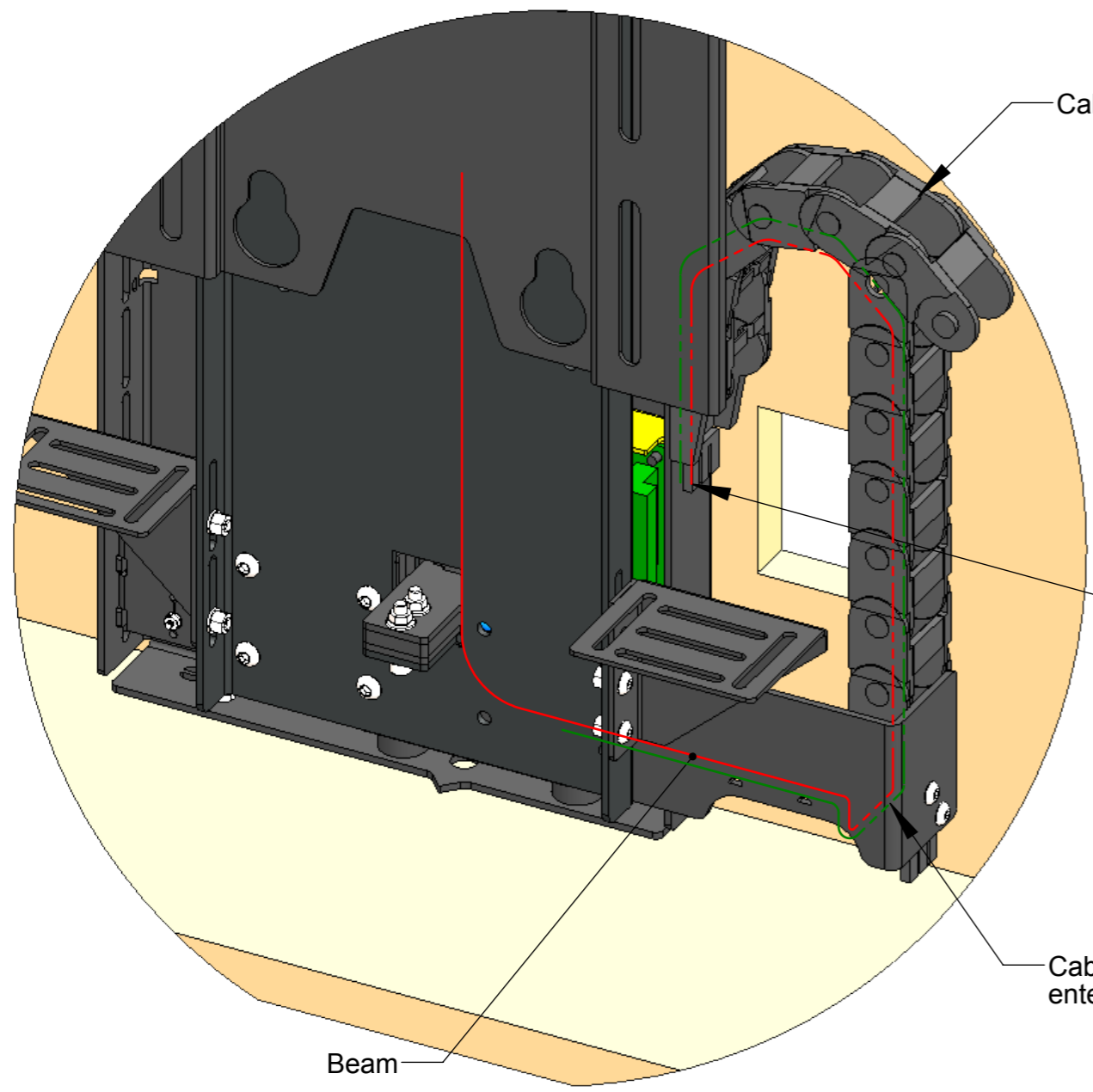

DETAIL A

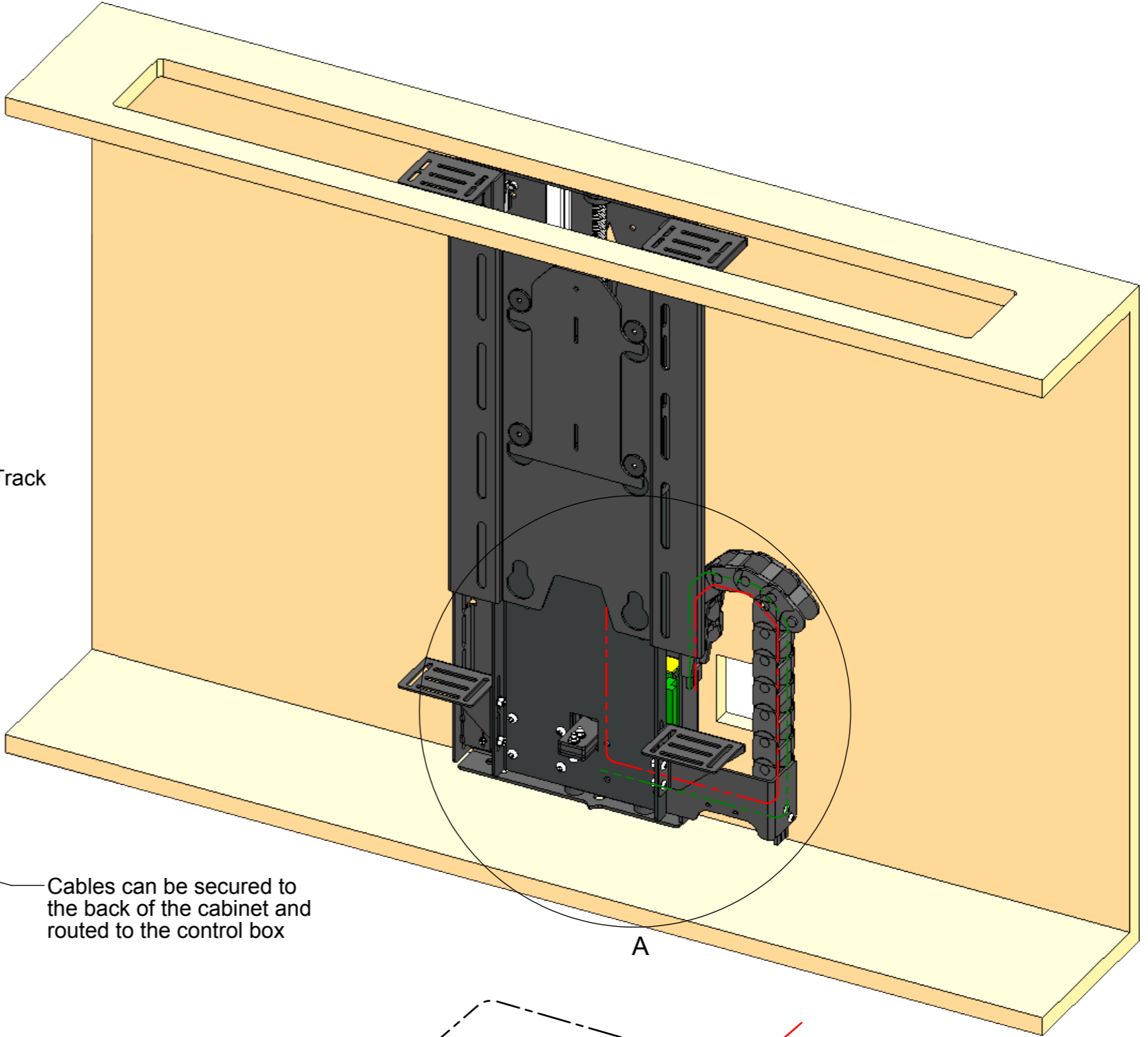

Cables can be secured to the back of the cabinet and routed to the control box

Cables exit Beam and enter Cable Track

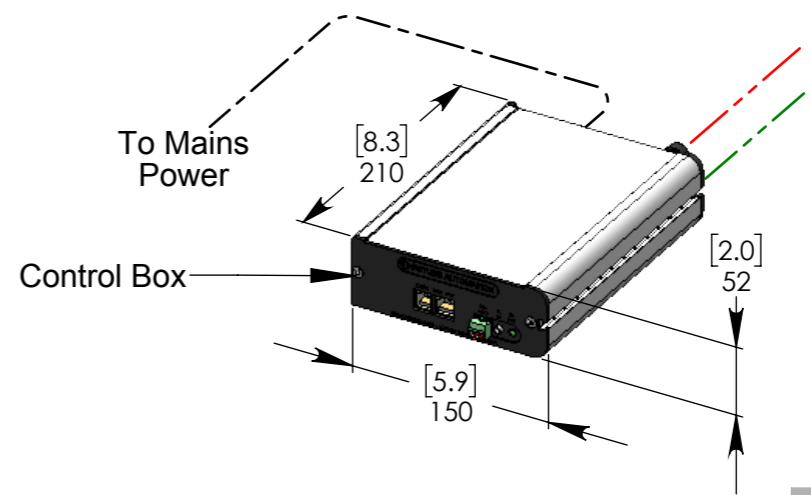

Mechanism Up - In Cabinet

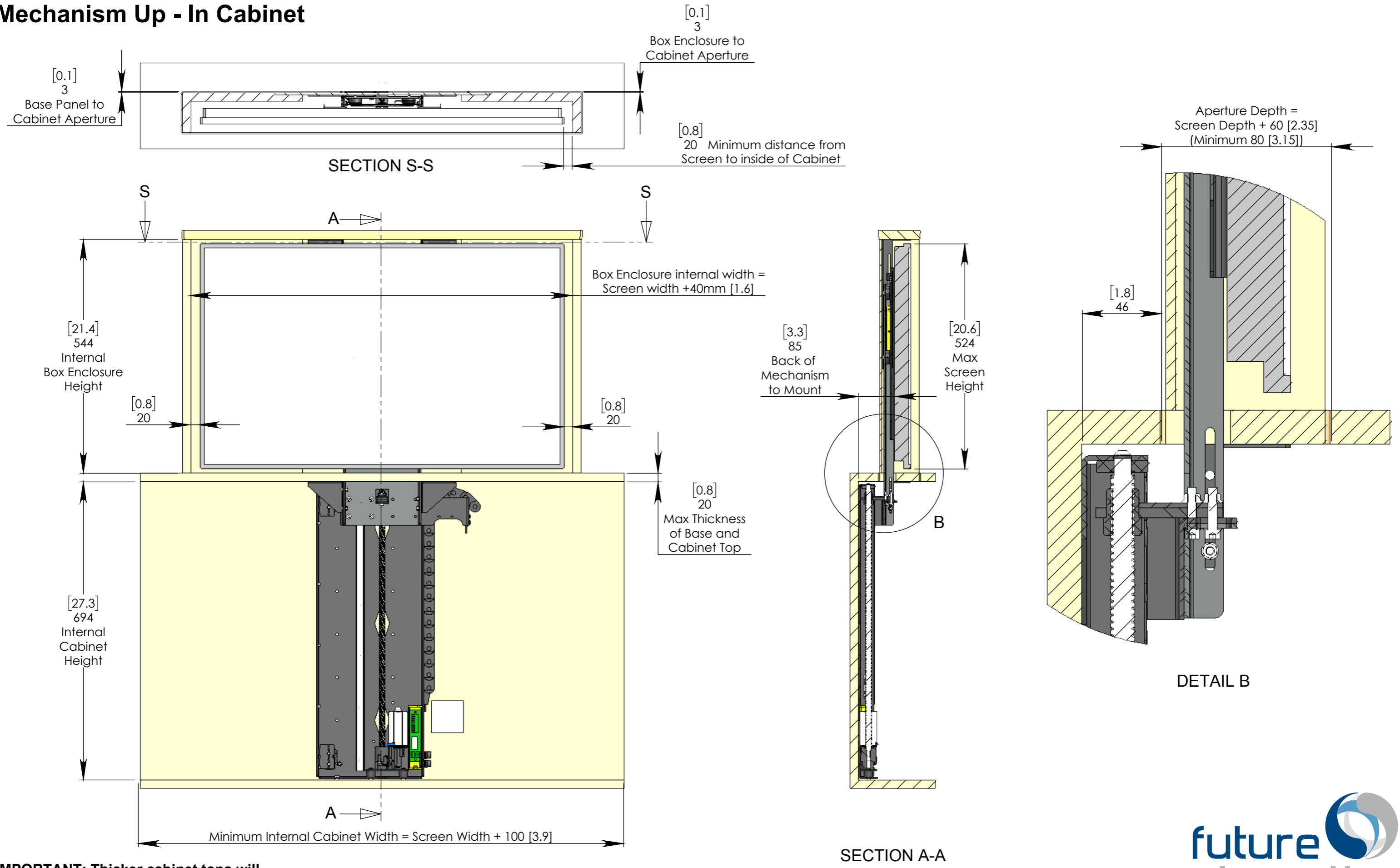

IMPORTANT: Thicker cabinet tops will require a reduced maximum screen height

Mechanism Down - In Cabinet

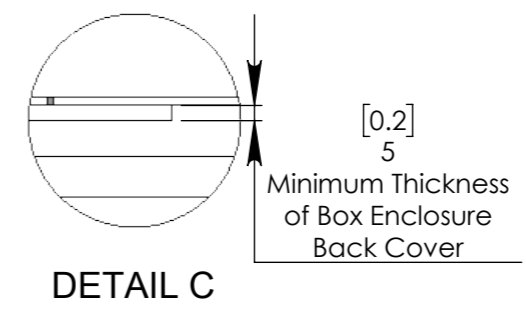
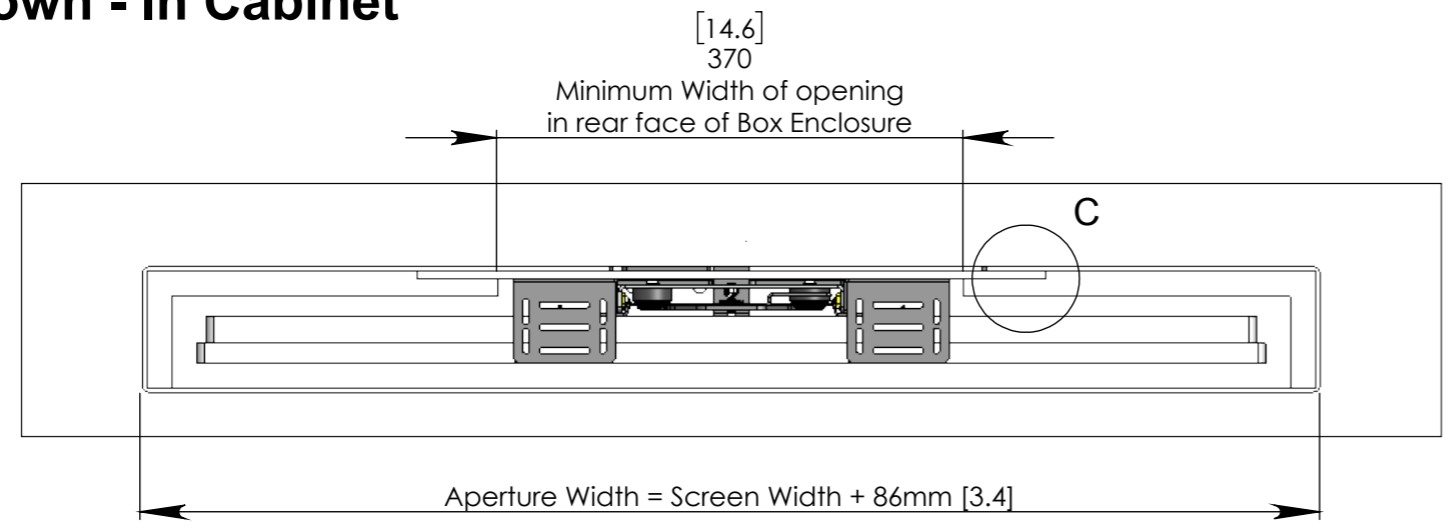

Shown with a tapered Box Enclosure Lid in a square Cabinet Aperture.

A tapered Cabinet Aperture can be used to improve the fit

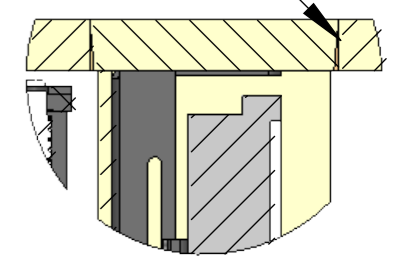

[3.3] 85
Back of Cabinet to Mount

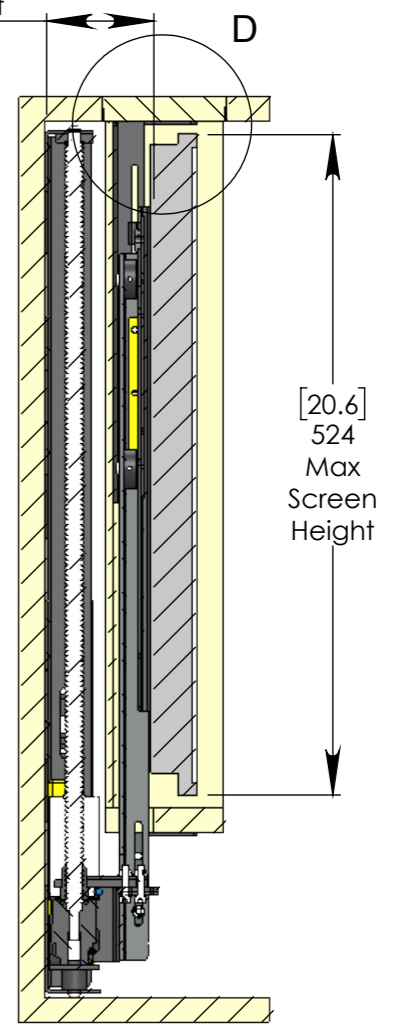

SECTION B-B

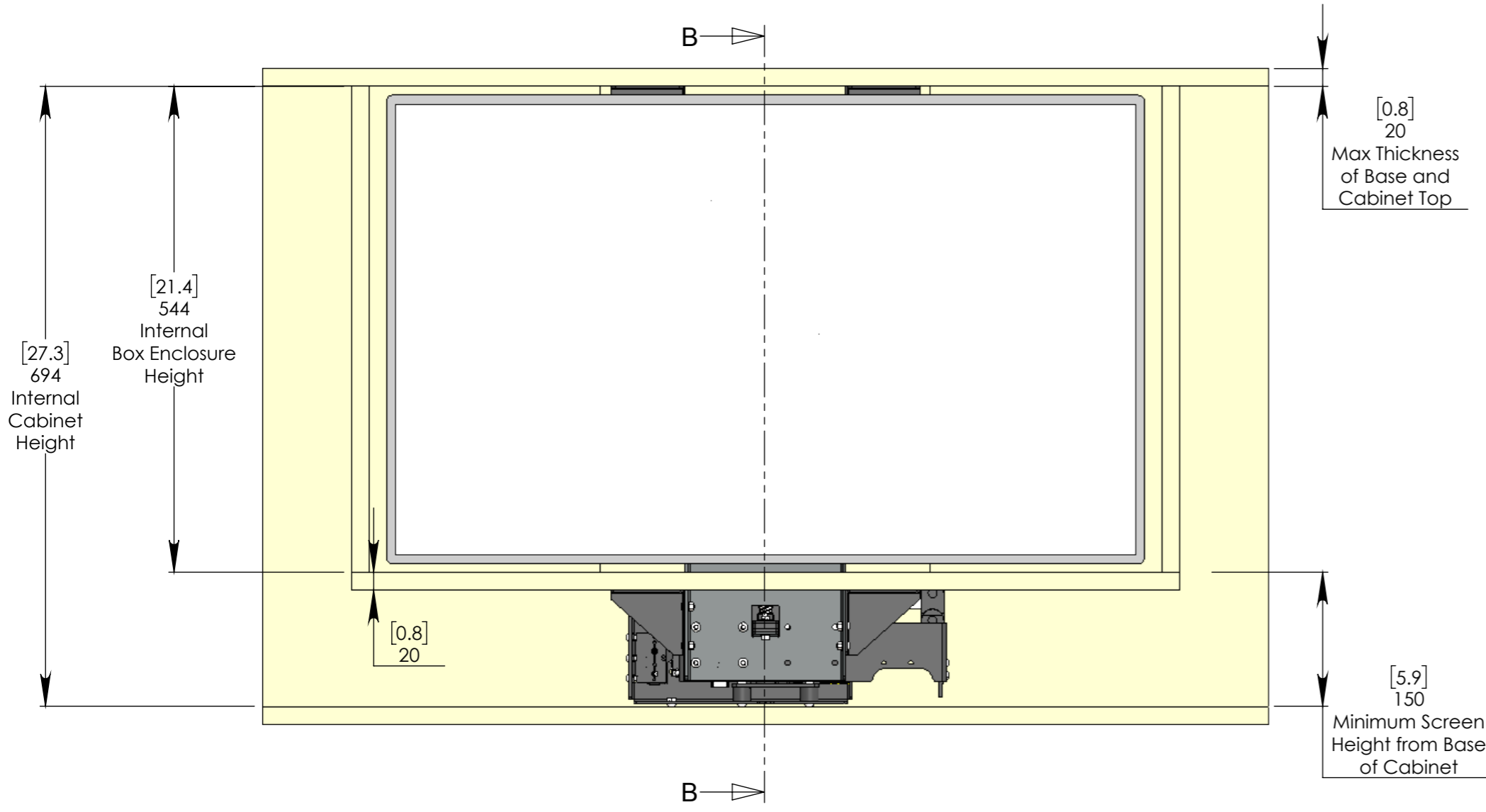

IMPORTANT: Thicker cabinet tops will require a reduced maximum screen height

Base Panel and Box Enclosure Lid Details

NOTE: A tapered Box Enclosure Lid creates a good fit in the Cabinet Aperture and helps the Box Enclosure to locate within the Cabinet.

BOX ENCLOSURE LID (TAPERED) - TOP VIEW

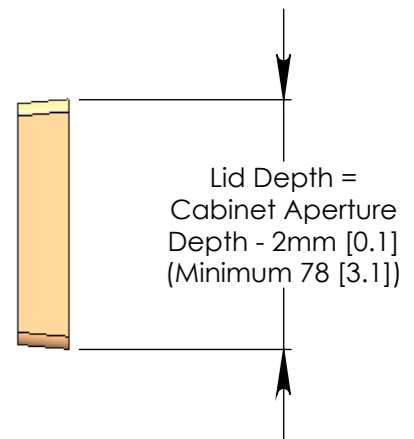
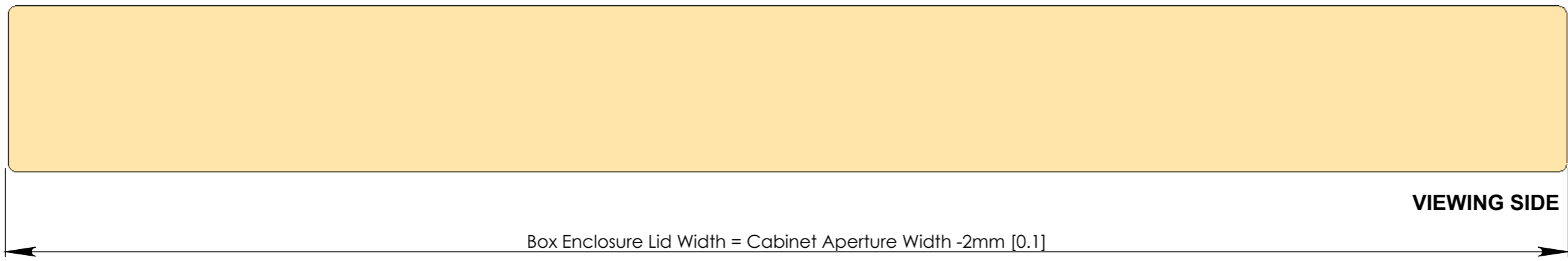

BASE PANEL - TOP VIEW

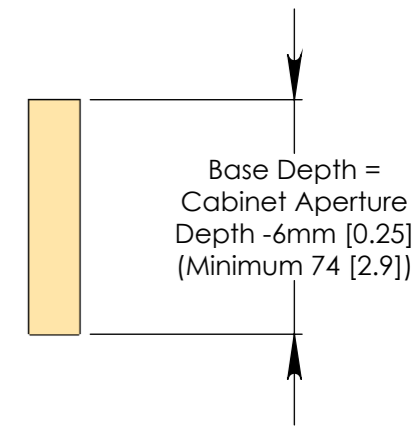
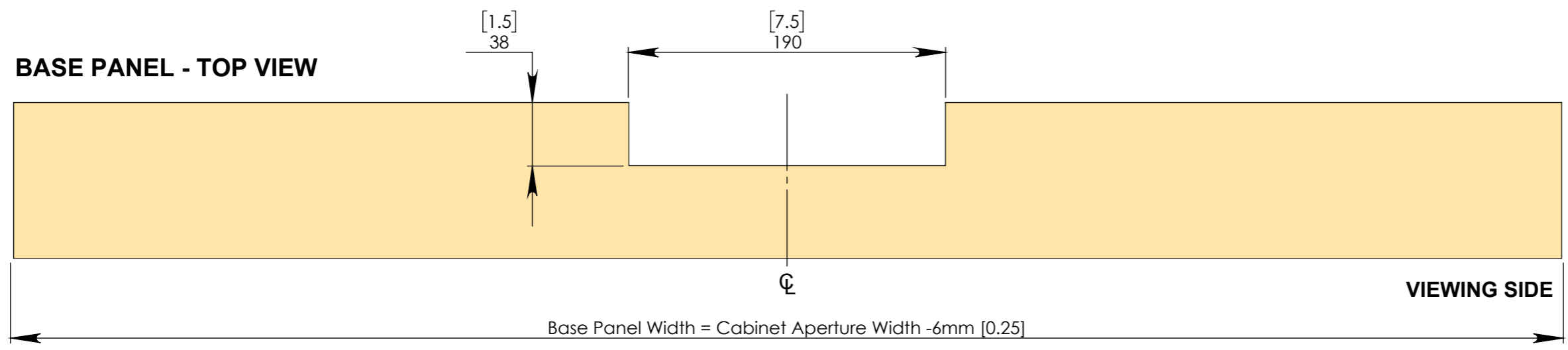

Overall Mechanism Dimensions

MECHANISM - UP POSITION

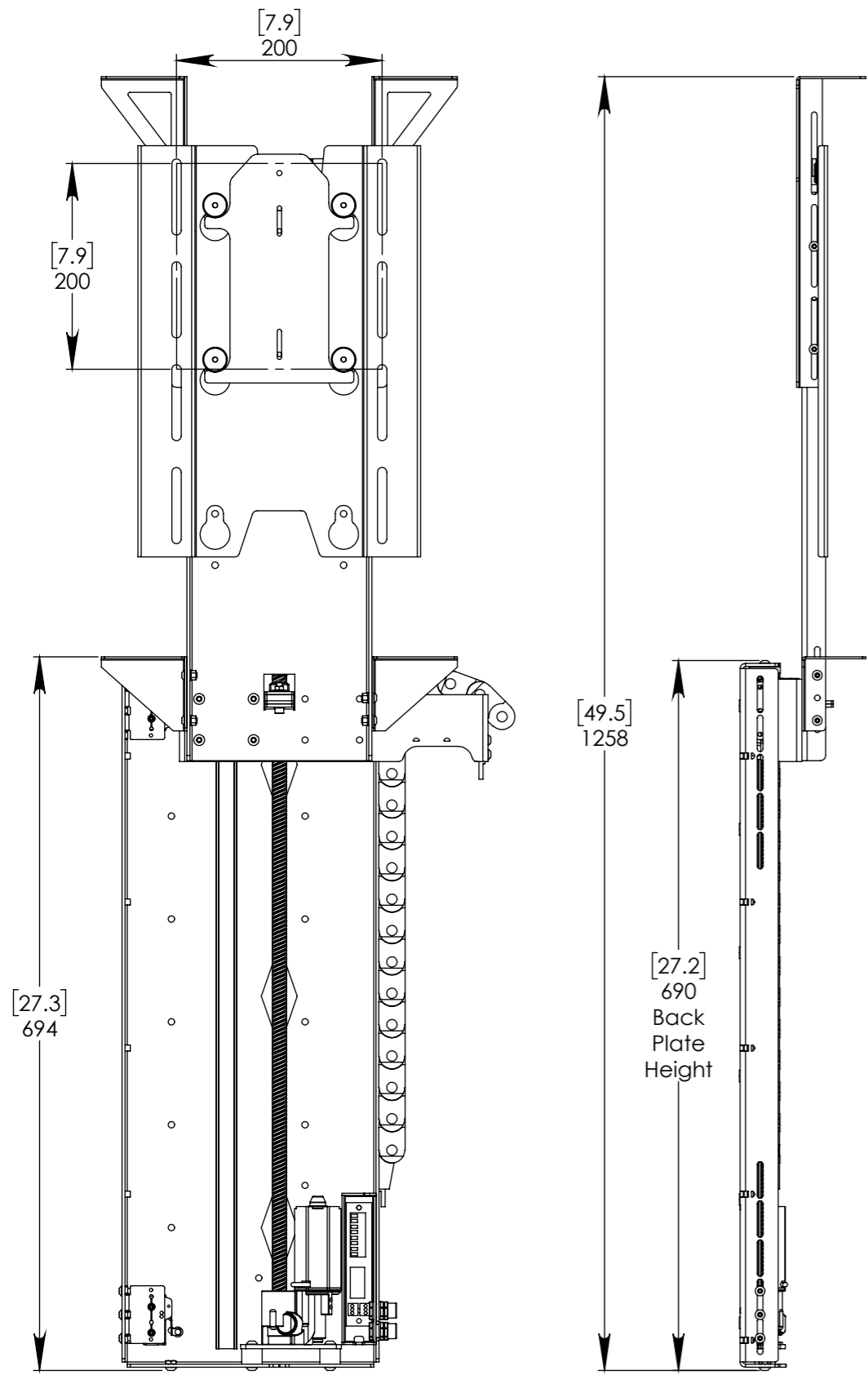

MECHANISM - DOWN POSITION

