



DESIGN HIGHLIGHTS

- Quiet smooth action at approximately 40mm [1.6] per second
- Full cable management
- Wide range of mounting options
- 24V DC motor. Suitable for direct DC supply
- Marine suitable robust beam

OPTIONS

- Box Enclosure
- Electric Flap Actuator
- Custom screen back cover
- Heavy duty option
- Outdoor Option

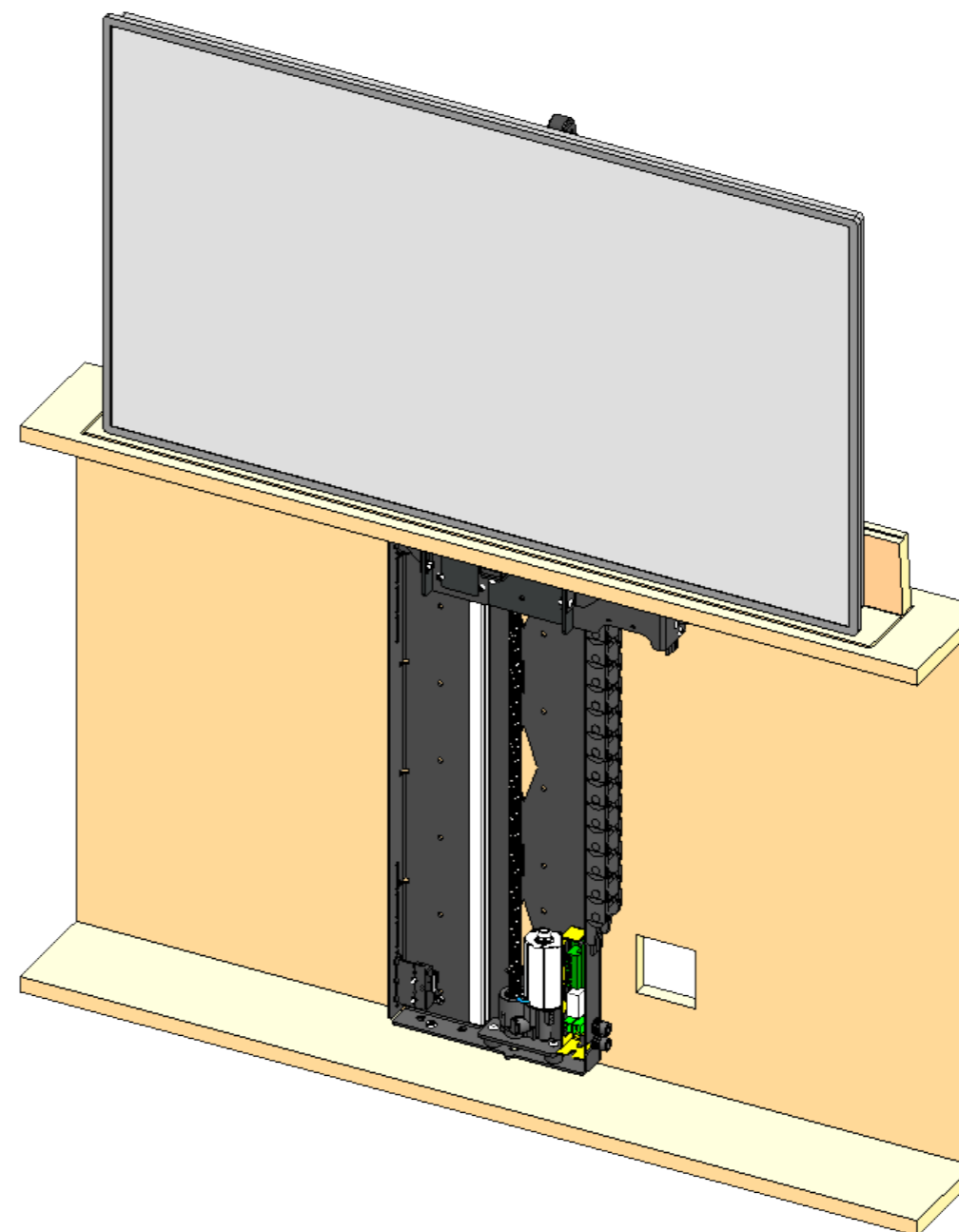
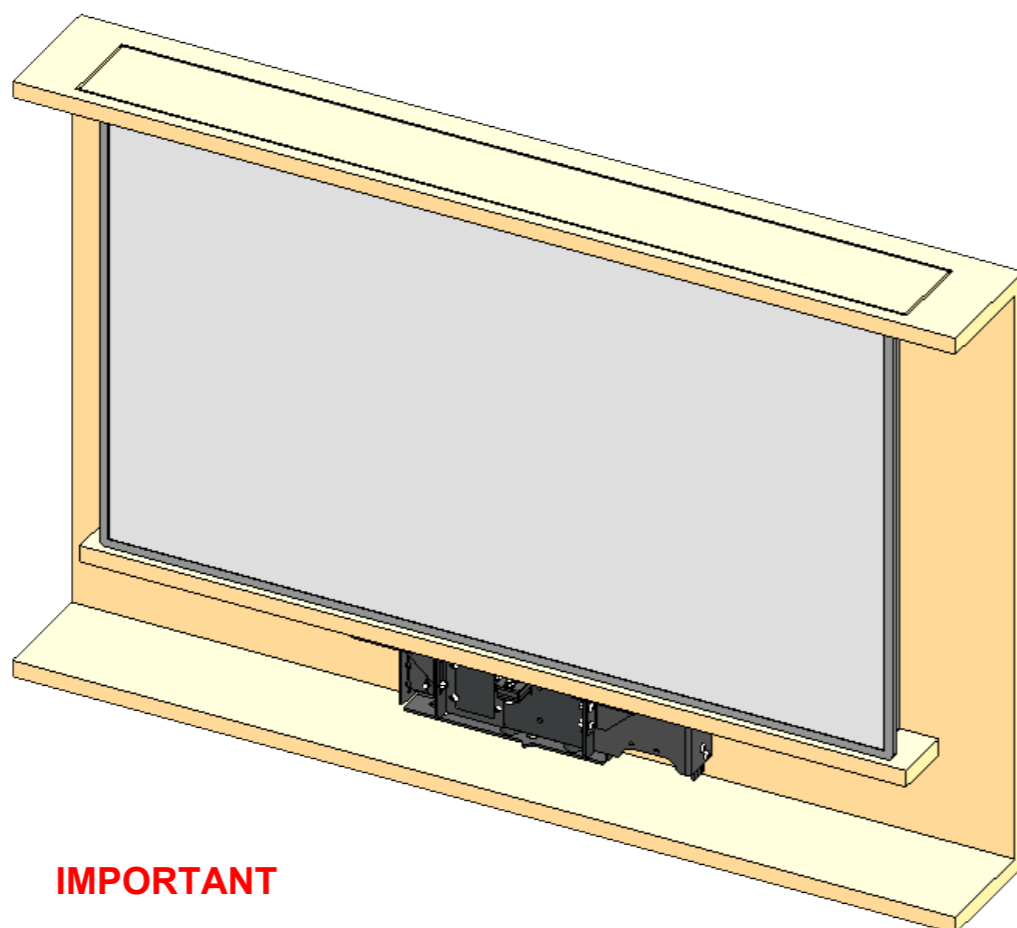

FUNCTION

An electric mechanism to lift a flat screen television. Suitable for marine use. Shown here for use with a Push Up Flap.

SUITABILITY

Suitable for a total lifting weight of 25Kg [55lbs] or 16Kg [35lbs] in a marine environment.

Maximum screen height 539mm [21.2]

Lift systems to suit different screen heights and weights are available

SPECIFYING

Check screen mounting details and request a suitable mount plate

CONTROL

Supplied with basic infrared remote. Can be learnt by many learning remotes.

Also has switch control and RS232 so can be operated by relays, switches, Crestron / AMX or Lutron systems.

WARNING

It is the responsibility of the installer to warn all potential end users of the dangers of interfering with mechanisms during operation

IMPORTANT

Mechanisms which lift or move weights need to be checked on a yearly basis for any damage which may result in an accident

Design Highlights

A space efficient and robust lifting mechanism, suitable for use in marine environments.

A robust 24V DC motor with a purpose made lead screw enables a quiet and smooth lifting action at approximately 40mm [1.6] per second.

A high precision linear guideway ensures stability and durability of the beam to prevent any unwanted movement of the screen.

Adjustable UP and DOWN positions allow for a precise final setup within the cabinet.

Full cable management protects all screen and power cables from damage and is easily accessible for future changes to the AV setup.

A wide range of mounting options are available to suit different screens and speaker arrangements.

The push flap roller provides a simple and easily adjustable method of opening and closing the cabinet flap automatically.

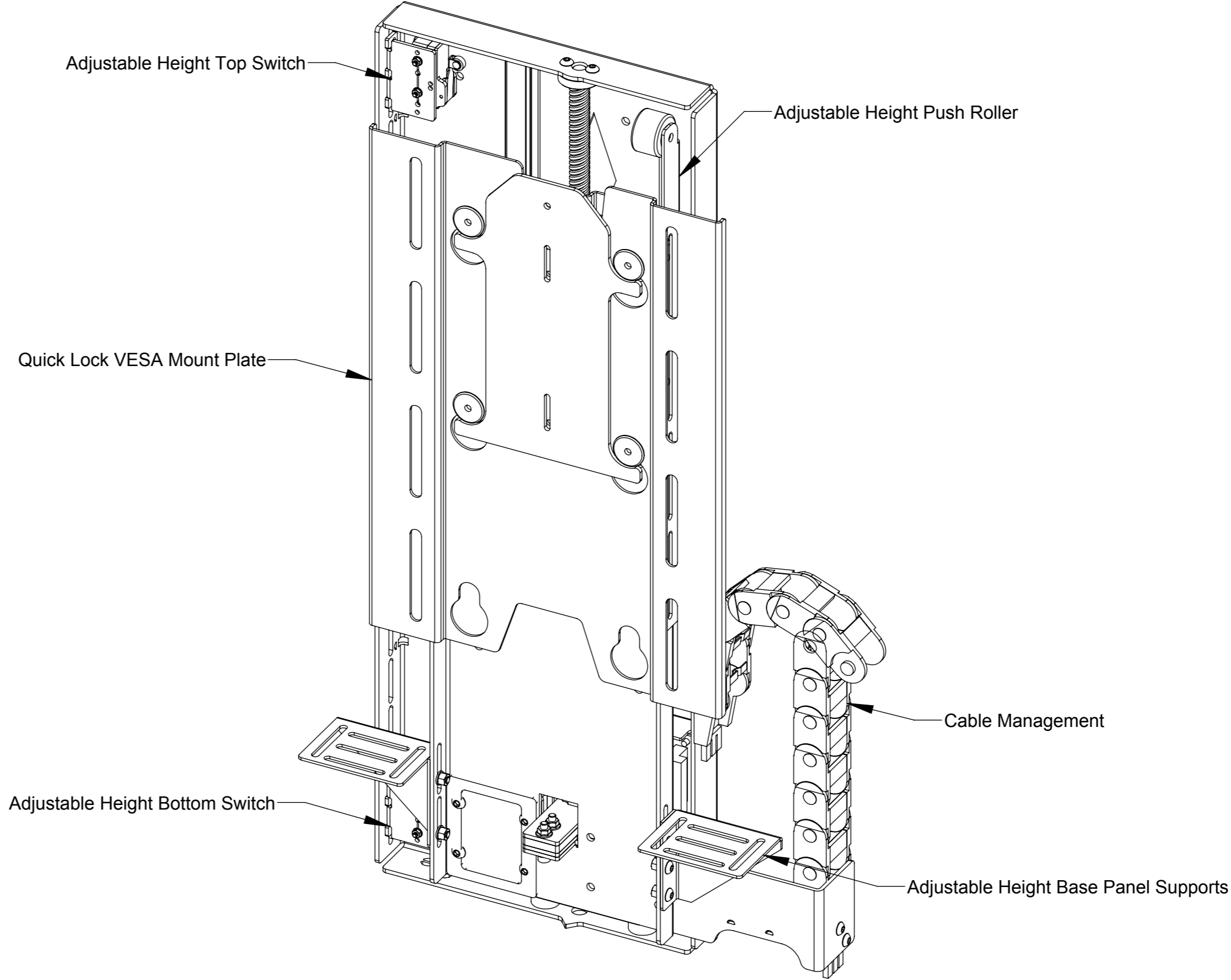

Cable Routing

Screen cables are routed behind the Base Panel and out the right side of the Beam into the Cable Track. Cables must be routed carefully to prevent any interference with the LSL beam as it operates.

Screen and Mechanism cables should be routed to a control box in the bottom of the cabinet.

- SCREEN CABLE
- MECHANISM CABLE
- POWER CABLE

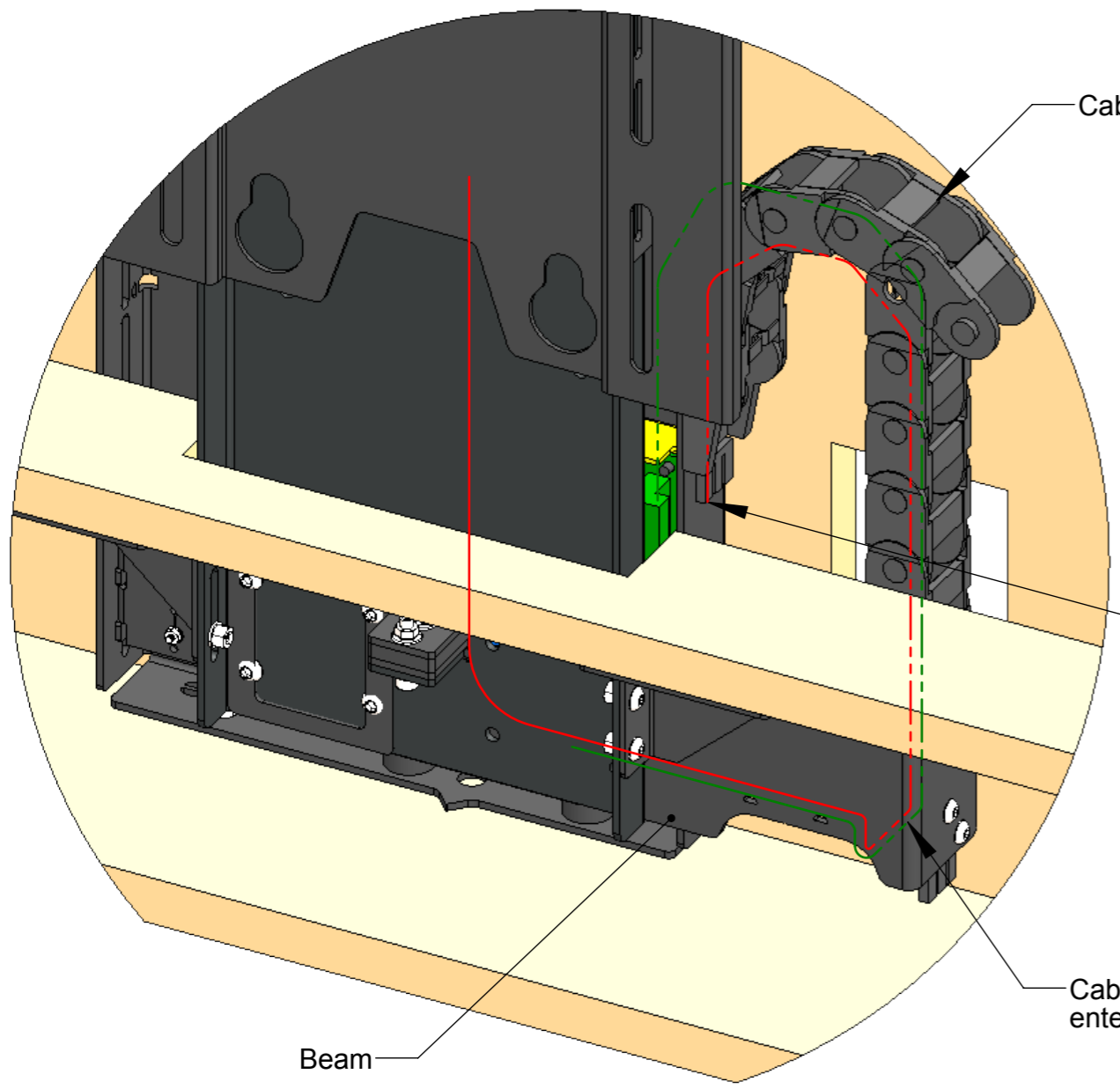

DETAIL A

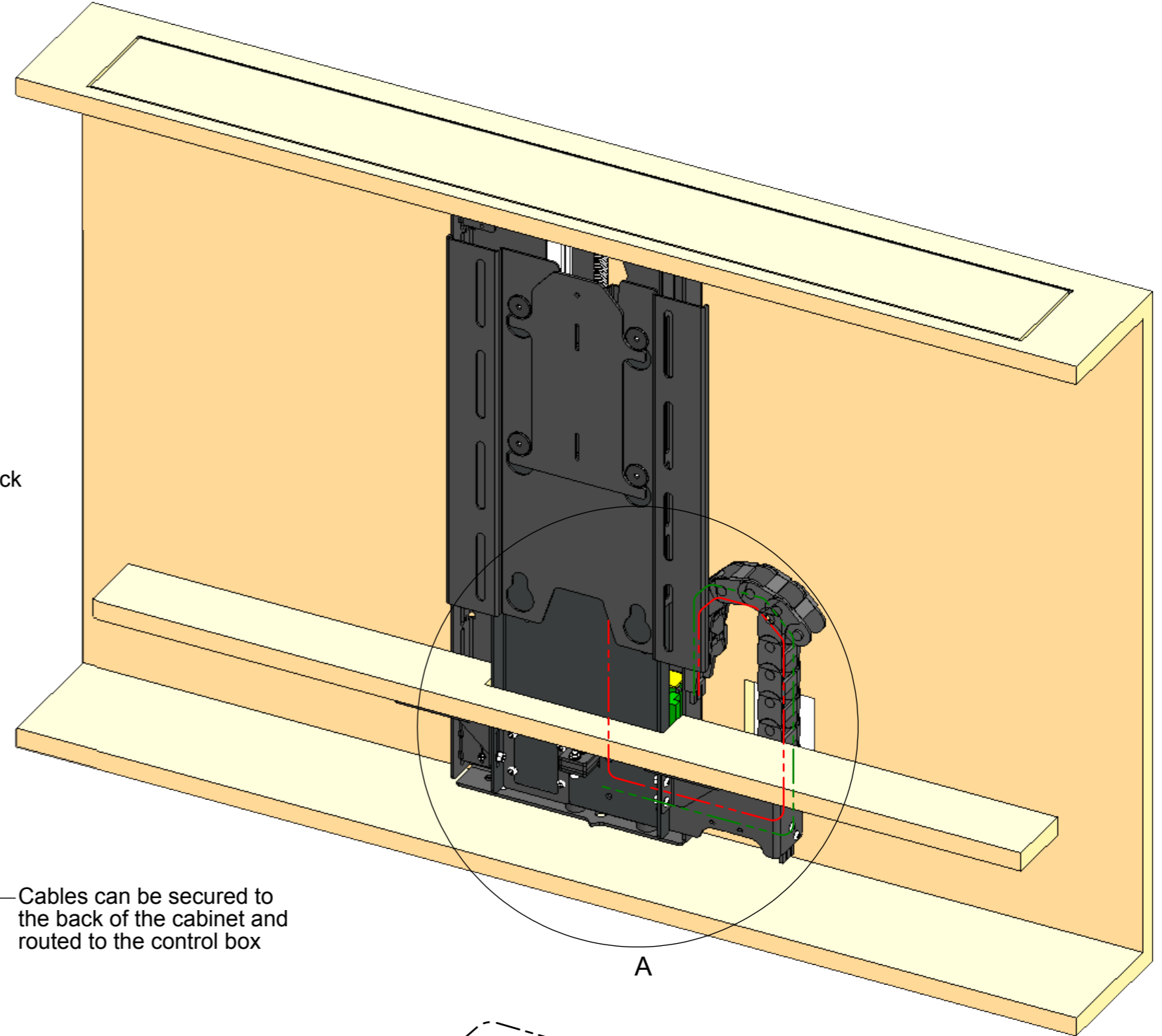

Cables can be secured to the back of the cabinet and routed to the control box

Cables exit Beam and enter Cable Track

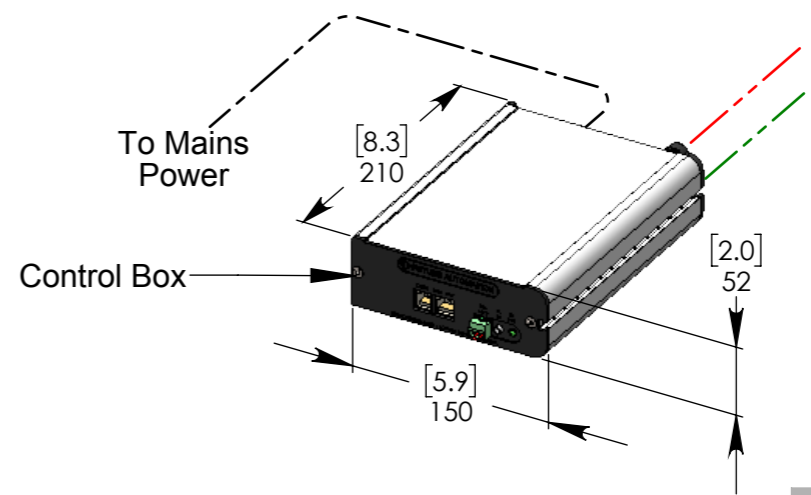

Mechanism Up - In Cabinet

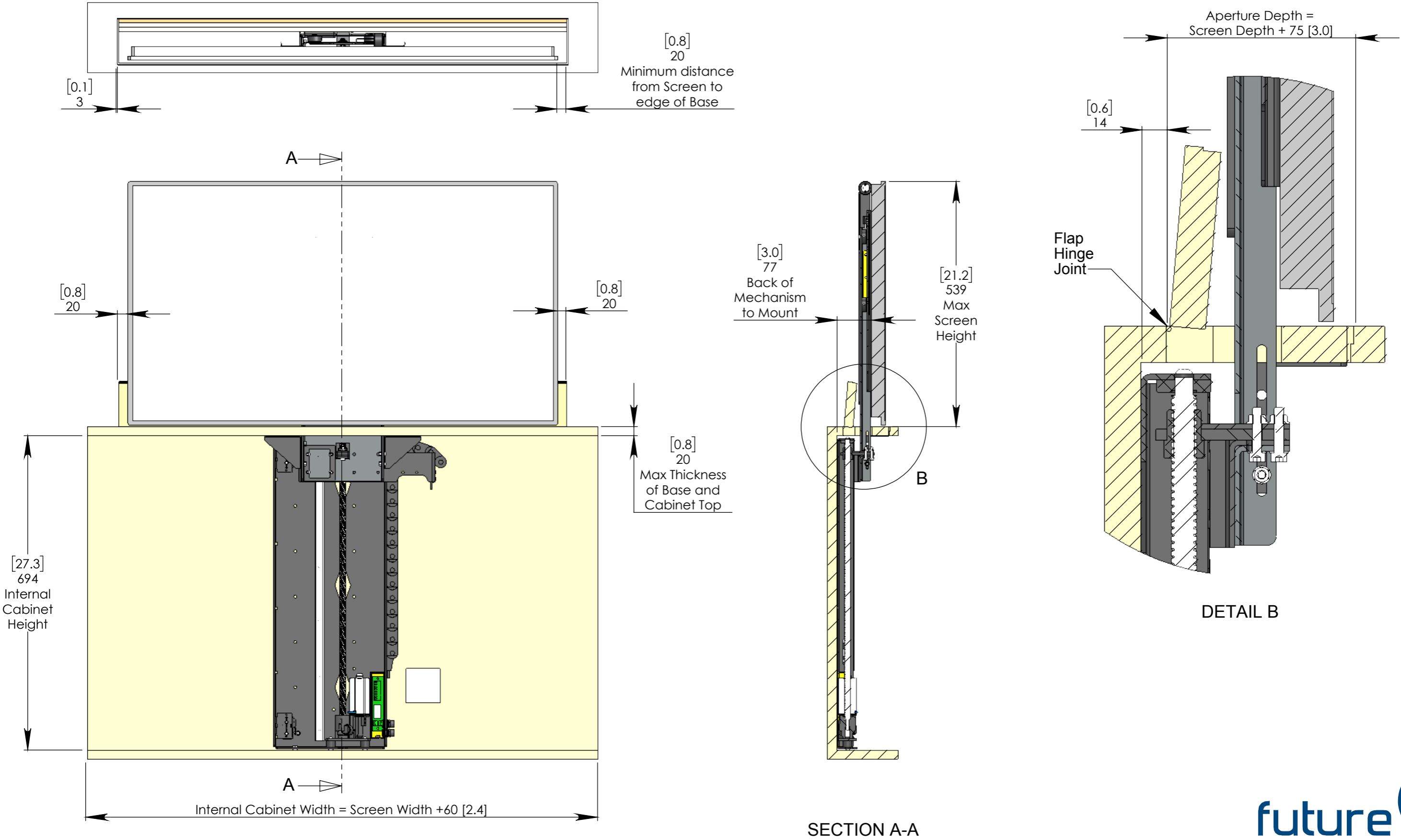

IMPORTANT: Thicker cabinet tops will require a reduced maximum screen height

Mechanism Down - In Cabinet

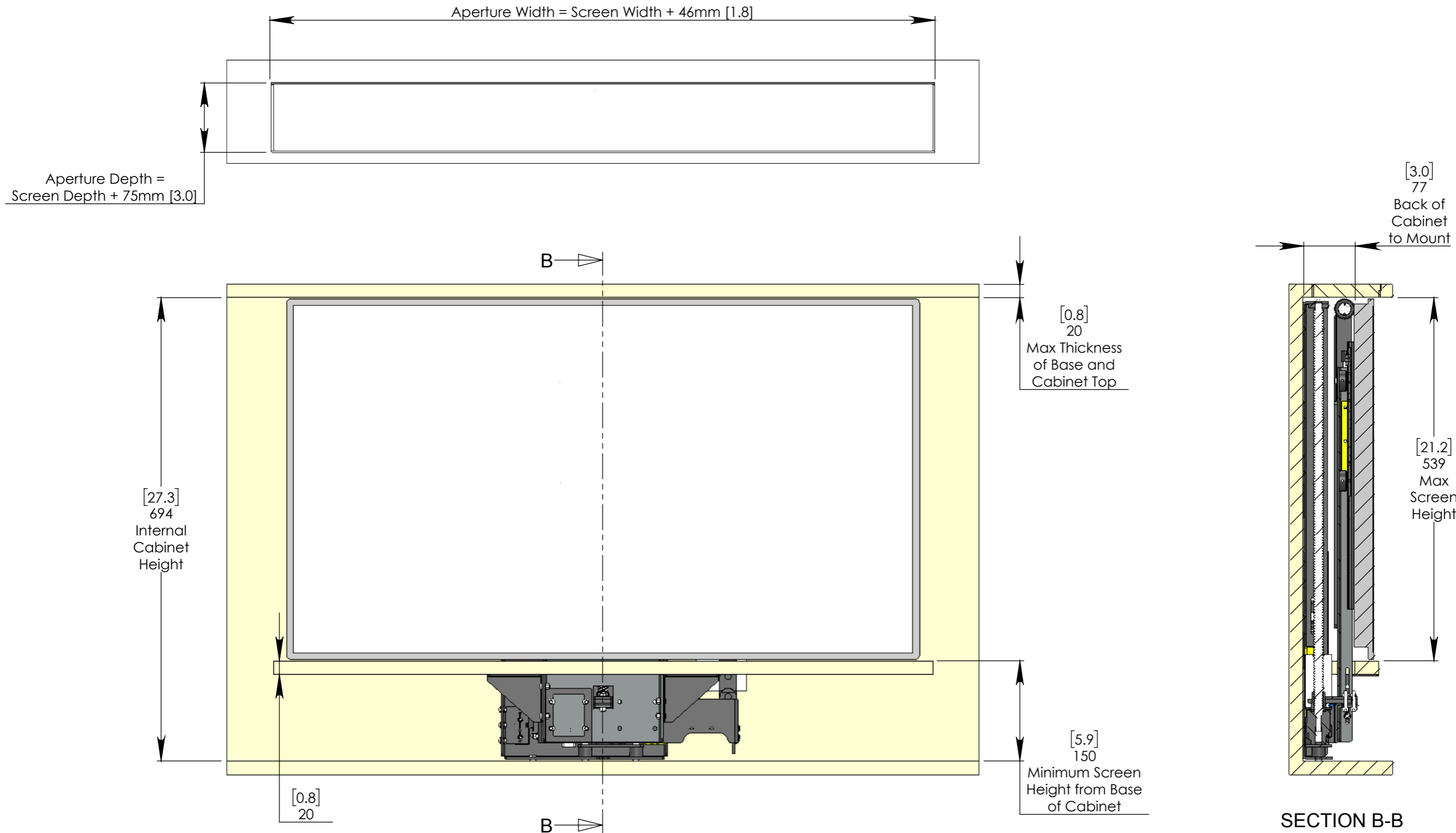

IMPORTANT: Thicker cabinet tops will require a reduced maximum screen height

Base Panel and Flap Panel Details

Flap depth dimensions are based on a 3mm thick piano hinge
 Required flap dimensions may vary dependant on the hinge used

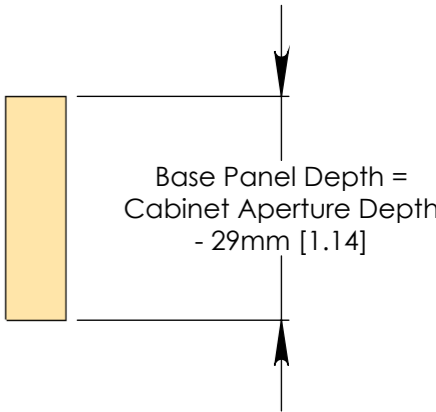
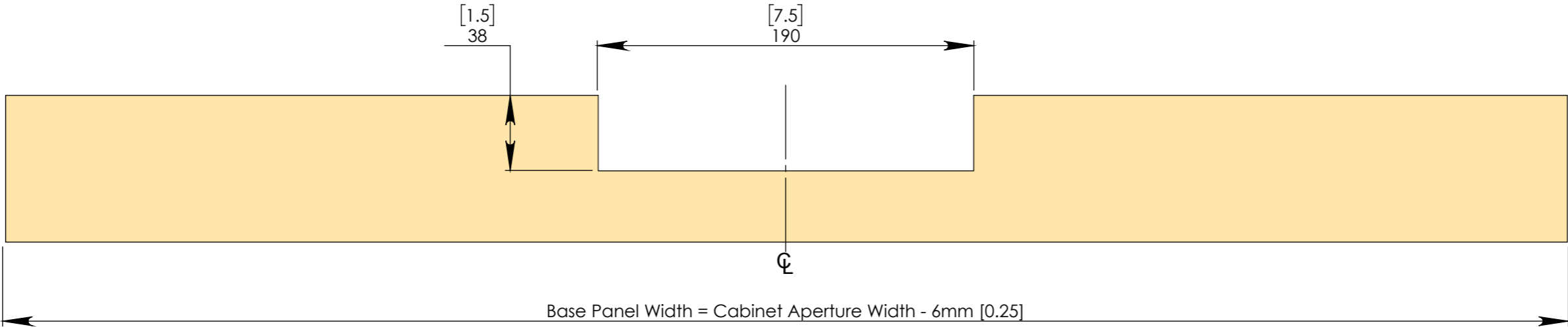
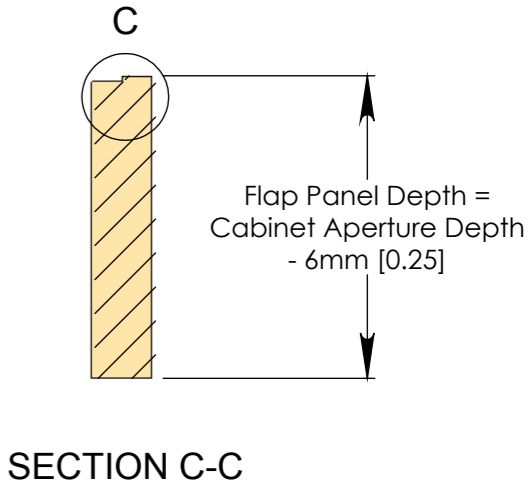
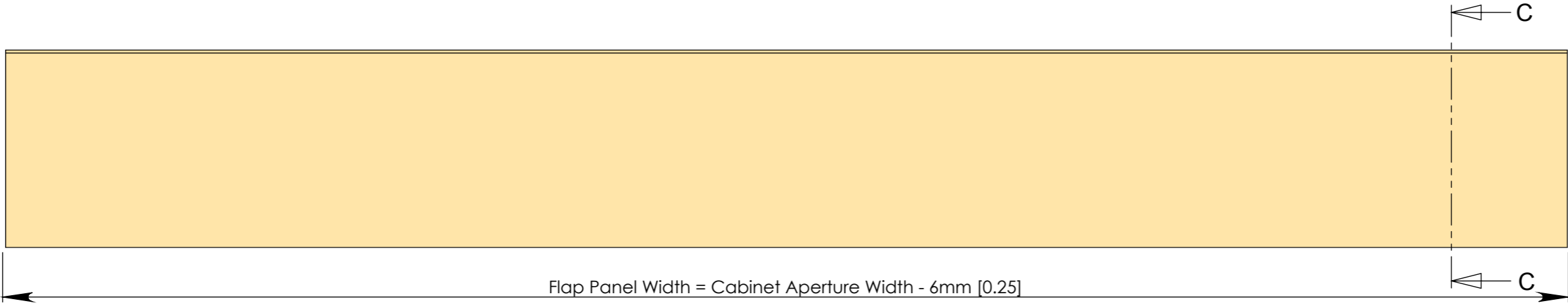
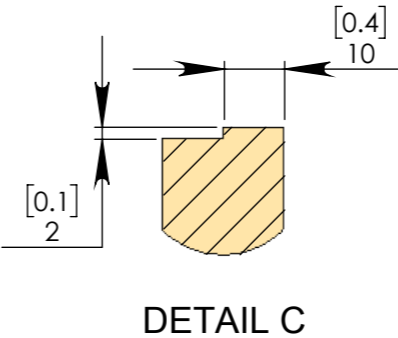

Overall Mechanism Dimensions

MECHANISM - UP POSITION

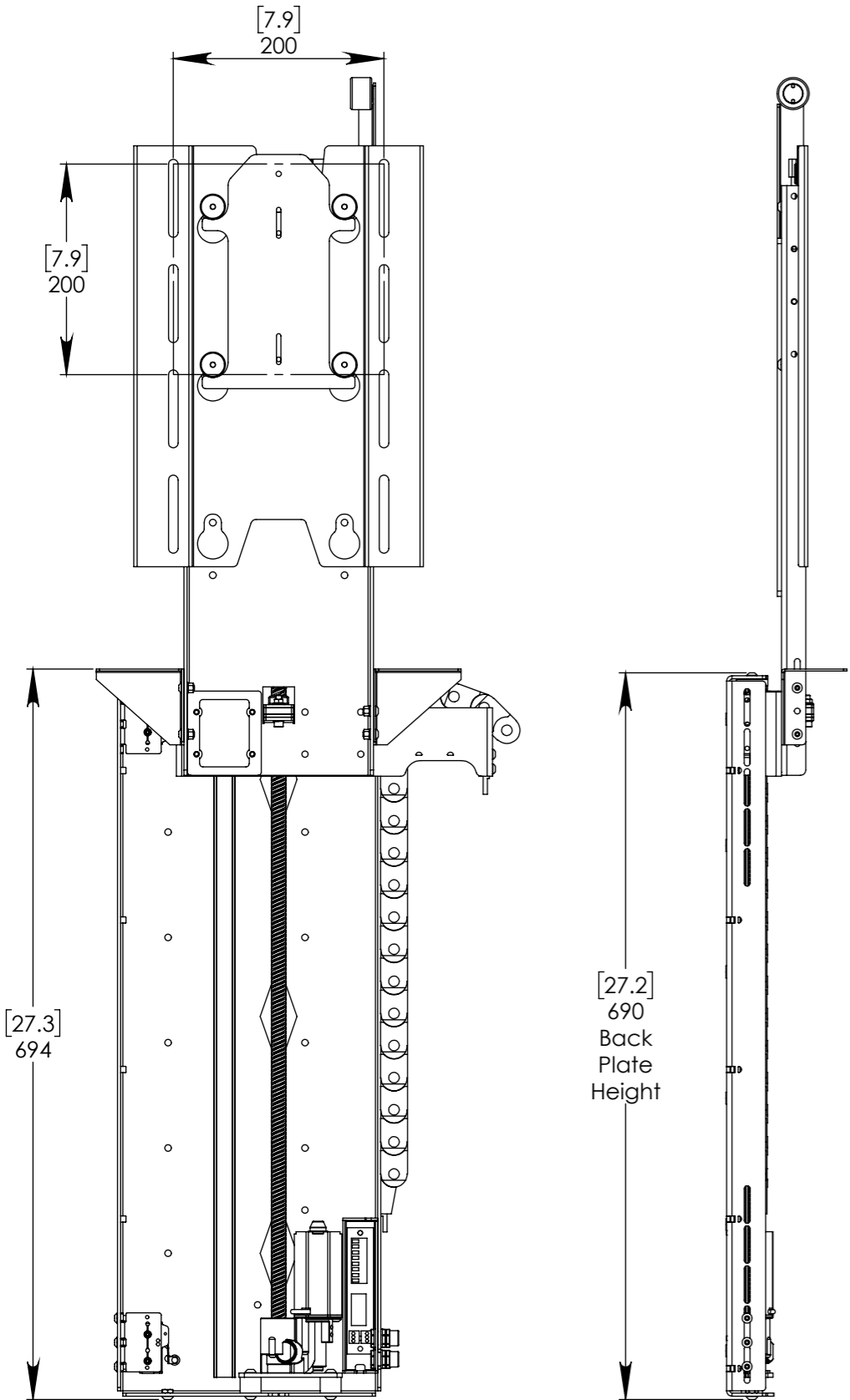

MECHANISM - DOWN POSITION

