

Installation Instructions

LSL BE - Lift System Light Box Enclosure

Design Highlights

- Quiet Smooth Lifting Action at Approximately 40mm [1.6"] per Second
- Full Cable Management
- Wide Range of Mounting Options
- 24V DC Motor. Suitable for Direct DC Supply
- Marine Suitable Robust Beam



Thank you for choosing
futureautomation

LSL BE - Lift System Light Box Enclosure



Caution
Warning



Beware of
Moving Parts



Danger
Electricity



Keep Hands
Clear

Safety Disclaimer

Important Safety Instructions

Explanation of graphical symbols

-(Electric Shock Symbol) = The lightning flash within an equilateral triangle is intended to alert you to the presence of un-insulated "dangerous voltage" within the products enclosure that may be of sufficient magnitude to constitute an electric shock to persons

-(Caution Symbol) = The exclamation point within an equilateral triangle is intended to alert you to the presence of important operating and maintenance (servicing) instructions in the literature accompanying the product

-(Tools Symbols) = The tools symbol within a coloured square are intended to highlight the required tools necessary for correct and safe installation of the product. These are intended as a guide only, and it is at the installer's discretion as to which tools are used.

WARNING: RISK OF ELECTRIC SHOCK, ONLY AUTHORIZED INSTALLERS TO OPEN THE POWER CONTROL BOX.

WARNING: To reduce the risk of fire or electric shock, do not expose electrical parts to rain or moisture, unless the product has been specifically designed to do so.

WARNING: Failure to provide adequate structural strengthening, prior to installation can result in serious personal injury or damage to the equipment. It is the installer's responsibility to ensure the structure to which the component is affixed can support the four times the weight of the component.

WARNING: Do not exceed the weight capacity. This can result in serious personal injury or damage to the equipment. It is the installer's responsibility to ensure that the total combined weight of all attached components does not exceed that of the maximum figure stated.

WARNING: Failure to provide adequate structural strength for this component can result in serious personal injury or damage to equipment! It is the installer's responsibility to make sure the structure to which this component is attached can support five times the combined weight of all equipment. Reinforce the structure as required before installing the component.

Warnings:

1. **Read all technical instructions fully before installation and use. It is the installer's responsibility to ensure that all documentation is passed on to the end user and read fully before operation.**
2. **Keep all documentation.**
3. **Heed all warnings.**
4. **Follow all technical specifications and instructions during installation.**
5. **Do not use near water unless the product has been specifically designed to do so.**
6. **Clean only with a dry cloth.**
7. **Do not defeat the purpose of the polarized or grounding type plug. A polarized plug has two blades, one wider than the other. A grounding type plug has two blades and a grounding prong. The wide blade or third prong are provided for your safety. If the provided plug does not fit your outlet, consult an electrician or contact the manufacturer.**
8. **Protect the power cord from being walked on or pinched, particularly at plugs, convenience receptacles, and the point where the exit from the apparatus.**
9. **Unplug the apparatus during lightning storms or when unused for long periods of time.**
10. **Only use attachments/accessories specified by the manufacturer.**
11. **Refer all servicing to qualified personnel. Servicing is required regularly on an annual basis, when the apparatus is damaged in any way, liquid has been spilled or objects have fallen into the apparatus, the apparatus has been exposed to rain or moisture, does not operate normally, or has been dropped.**
12. **To completely disconnect the apparatus from the AC mains, disconnect the power cord plug from the AC receptacle on the power control box.**
13. **To prevent overheating, do not cover the apparatus. Install in accordance with the instructions.**
14. **UK, Ireland and Hong Kong only – The power cord is supplied with a 13A plug having an earthing pin. The apparatus is earthed and this pin is not required for safety, merely to operate the safety shutter of mains outlet.**
15. **No naked flames such as lit candles should be placed on the unit.**
16. **Observe and follow the local regulations when disposing of batteries.**
17. **Do not expose the unit to dripping or splashing fluids.**
18. **Do not place objects filled with liquid, such as vases, on the unit.**
19. **Do not expose the batteries to excessive heat such as sunshine, fire or the like.**
20. **For all mounted apparatus, the apparatus should be installed on solid wood, bricks, concrete or solid wood columns and battens.**
21. **Always turn off power at source before putting on or taking off parts and cleaning.**
22. **Do not use outdoors unless marked for outdoor use.**
23. **Exceeding the weight capacity can result in serious personal injury or damage to equipment.**

Future Sound & Vision trading as Future Automation intend to make this and all documentation as accurate as possible. However, Future Automation makes no claim that the information contained herein covers all details, conditions or variations, nor does it provide for every possible contingency in connection with the installation or use of this product. The information contained in this document is subject to change without prior notice or obligation of any kind. Future Automation makes no representation of warranty, expressed or implied, regarding the information contained herein. Future Automation assumes no responsibility for accuracy, completeness or sufficiency of the information contained in this document.

LSL BE - Lift System Light Box Enclosure

Contents	Page
Introduction	
Safety Information	1
Contents	2
Contents	3
Tool Indicator Icons	3
Installation	
Parts List	
Package Contents	4
Stage 1	
Before You Start	5
Remove KH Screen Mount	5
Stage 2	
Fixing the Lift in the Cabinet	6
Stage 3	
KH Upright Assembly	7
Stage 4	
Mounting the Box Enclosure	8
Stage 5	
Attaching the Enclosure	9
Stage 6	
Routing the Cables & Screen Mount Plate Fixings	10
Stage 7	
Screen & Box Enclosure Mounting	11
Stage 8	
Switch Adjustments	12
Electrical Connections	
Contact Closure	13
RS232 Controls	14
IR Controls	15
Operations	
IR Control & Operation	15
Storing Positions	15
Changing Batteries	15
Trouble Shooting	16
Technical Overview	17
Notes	18

LSL BE - Lift System Light Box Enclosure

Contents

Page

Tool Indicator Icons

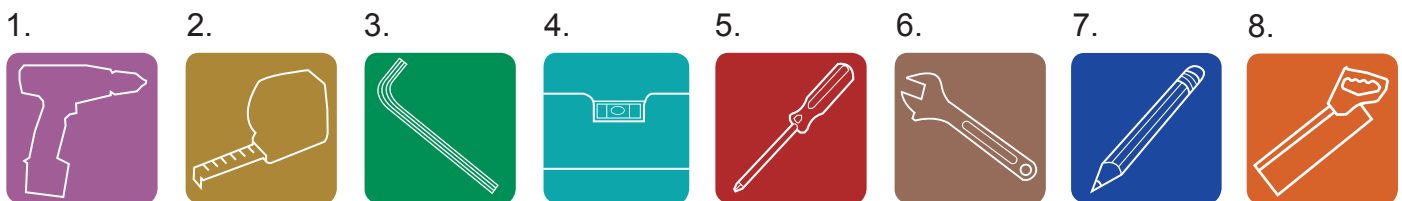

1. - Drill

2. - Tape measure

3. - Allen Keys

4. - Spirit Level

5. - Screwdrivers

6. - Spanners

7. - Pencil

8. - Saw

Product Warranty

This product carries a warranty that covers the cost of labour and spare parts incurred by any defects in materials and workmanship under normal use during a two year period from date of purchase. Support for any problems that are not hardware faults are excluded from the warranty entitlement. This warranty does not affect your statutory consumer rights.

The following is excluded from warranty service:

- Malfunctioning caused by misuse or damage, accidental or otherwise, or service modification by persons not authorised by Future Automation, or the use of any non Future Automation supplied parts;
- Any electrical, or other environmental work external to your Future Automation mechanism including power cuts, surges or lightning strikes;
- Additional items not supplied by Future Automation although they may have been supplied together by the retailer;
- Any 3rd party software products controlling your mechanism;
- Any transfer of ownership. Warranty is provided only to the initial purchaser;
- Compensation for loss of use of the product, and consequential loss of any kind;
- Use of the product over the specified weight capacity;
- Any damage to products during transit that is not checked and notified as "unchecked" or "damaged" upon receipt of delivery.

Any part of your system that needs to be replaced during a warranty repair becomes the property of Future Automation.

LSL BE - Lift System Light Box Enclosure

Package Contents

- 1 - Mechanism
- 1.1 - Back Plate
- 1.2 - Lifting Drive
- 1.3 - Base Panel Brackets
- 1.4 - KH Lifting Plate
- 1.5 - Screen Mount
- 1.6 - Cable Management
- 1.7 - Lid Mount Bracket
- 1.8 - Adjustable IN/OUT Switch

2 - Control Box

3 - Remote Control

Not Shown On Page

- 4 - x2 AAA Batteries
- 5 - Multi Pack Of Nuts, Bolts & Washers
- 6 - Mains Power & Other Leads

Nuts & Bolts Multipack:

A range of nuts, bolts, washers and spacers to help add in the mounting for your screen

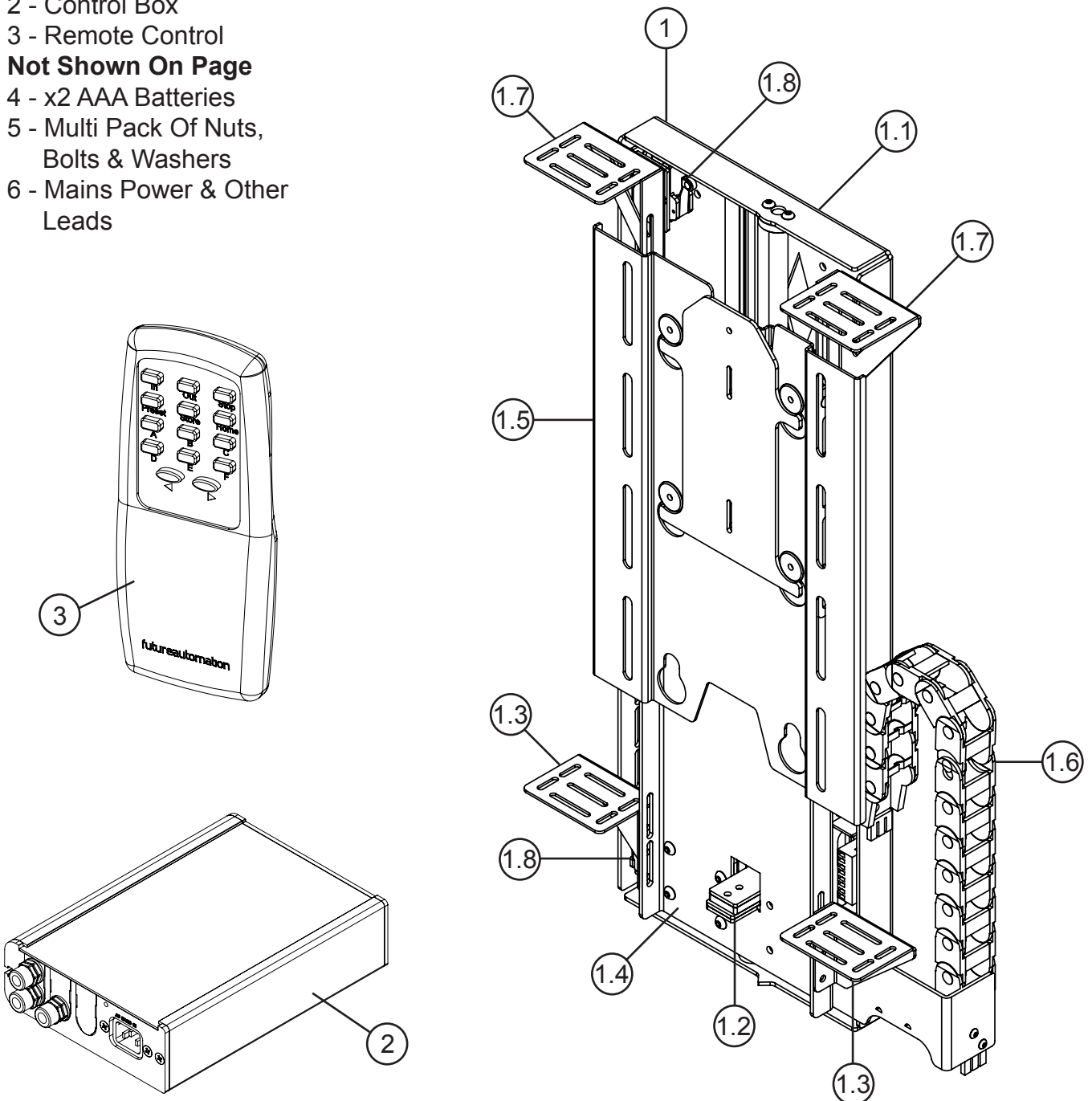

LSL BE - Lift System Light Box Enclosure



Before You Start

Check the Operation of the Mechanism.

Firstly, remove all the red cable ties which keep the mechanism safe and secure during transit.

Once they have all been removed, the mechanism can be powered up and tested.

Connect the supplied IR lead and check that the mechanism operates correctly before continuing with the installation.

Remove KH Screen Mount

Un-lock the KH mount plate but turning the locking lever 90 degrees and lift off the hook toggles.

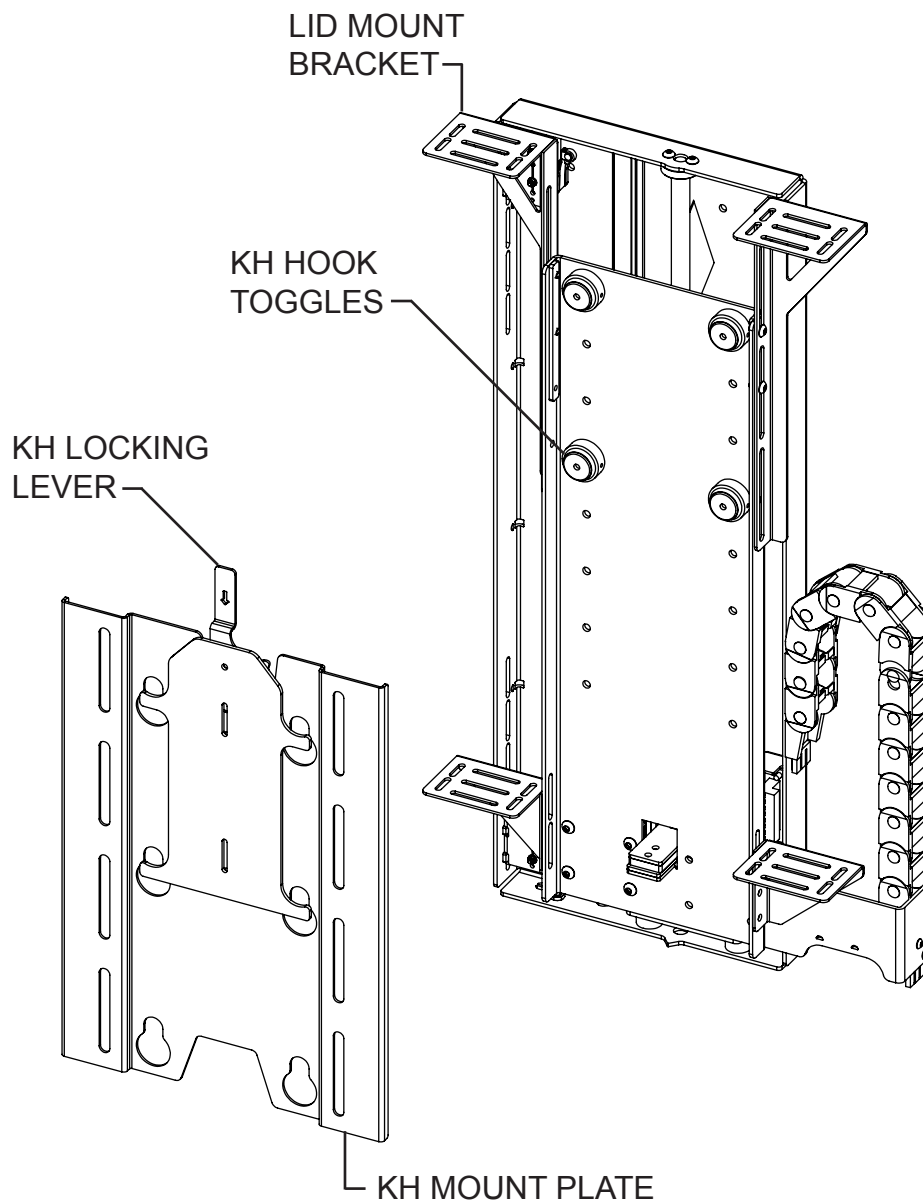

LSL BE - Lift System Light Box Enclosure



Fixing the Lift in the Cabinet

Place the mechanism within the cabinet. Fix the lift where possible down the back face. Make sure that the lifting plate is central by using the centre line marks on the back of the back face.

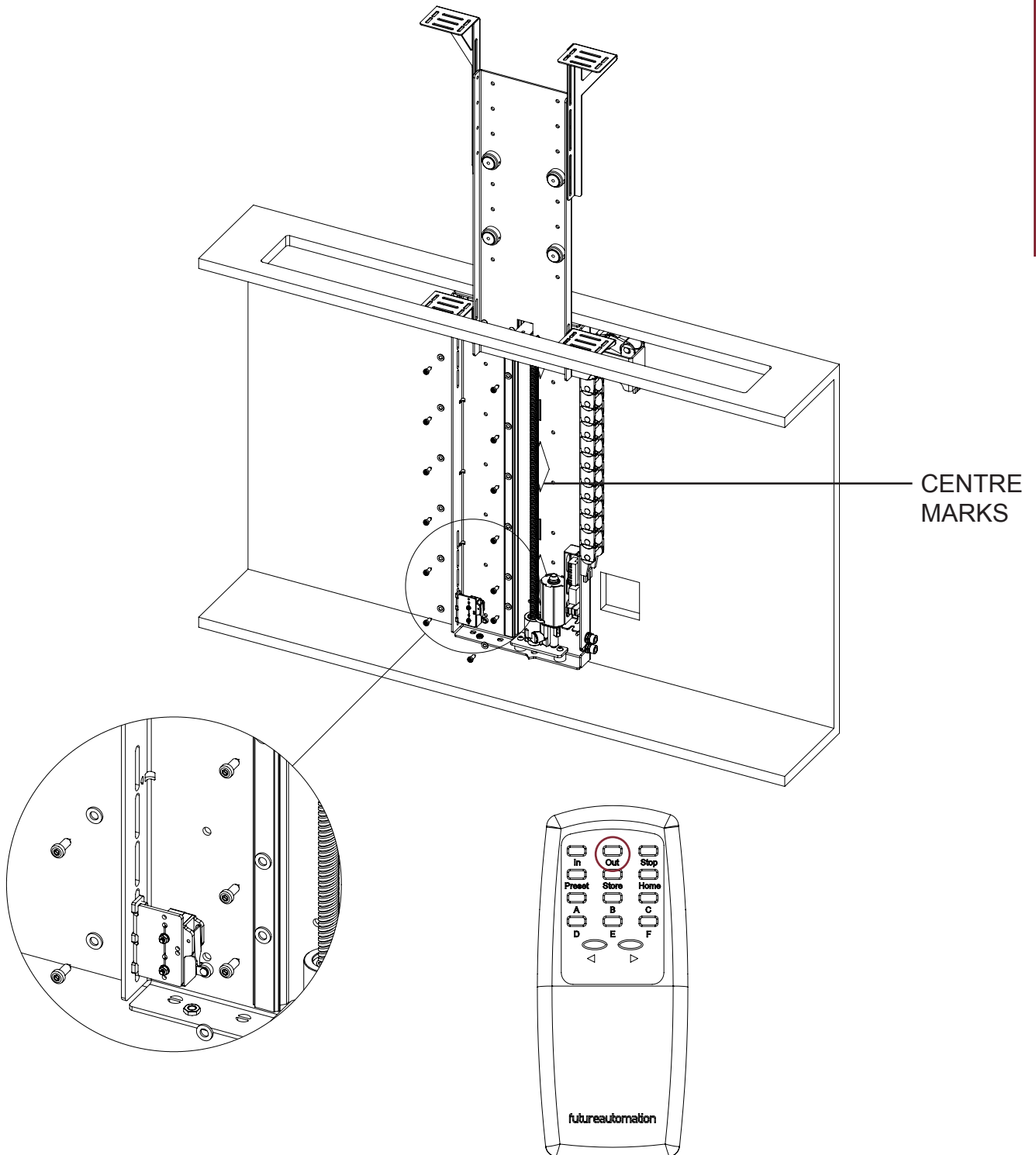

LSL BE - Lift System Light Box Enclosure



KH Upright Assembly

Below shows the KH UPRIGHT assembly. To release the SCREEN MOUNT PLATE rotate the top LOCKING LEVER and lift off the TOGGLES. The TOGGLES can adjust the height by moving up or down the KH UPRIGHT. The ENCLOSURE MOUNT BRACKETS fix to the side of the KH UPRIGHT and slide up and down to support the enclosure lid.

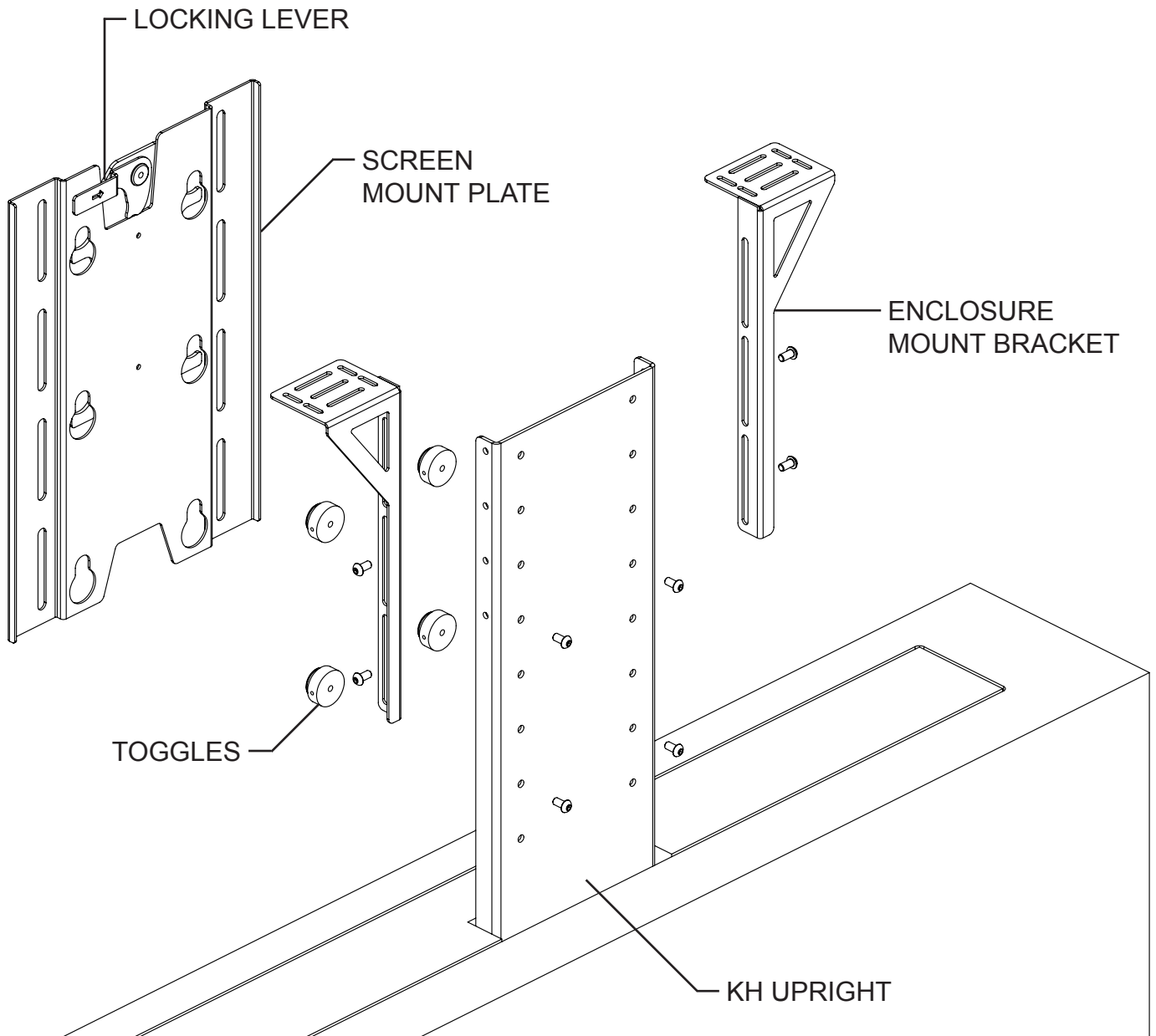

LSL BE - Lift System Light Box Enclosure



Mounting the Box Enclosure

After the mechanism is in the correct position the next step is to lower the BOX ENCLOSURE into place and fix from the underside through the BASE PANEL BRACKETS. A good tip is to place the BOX ENCLOSURE in place and draw marks from the underside through the BASE PANEL BRACKETS, then fix using a wood screw and a large penny washer, this will allow you to adjust the position.

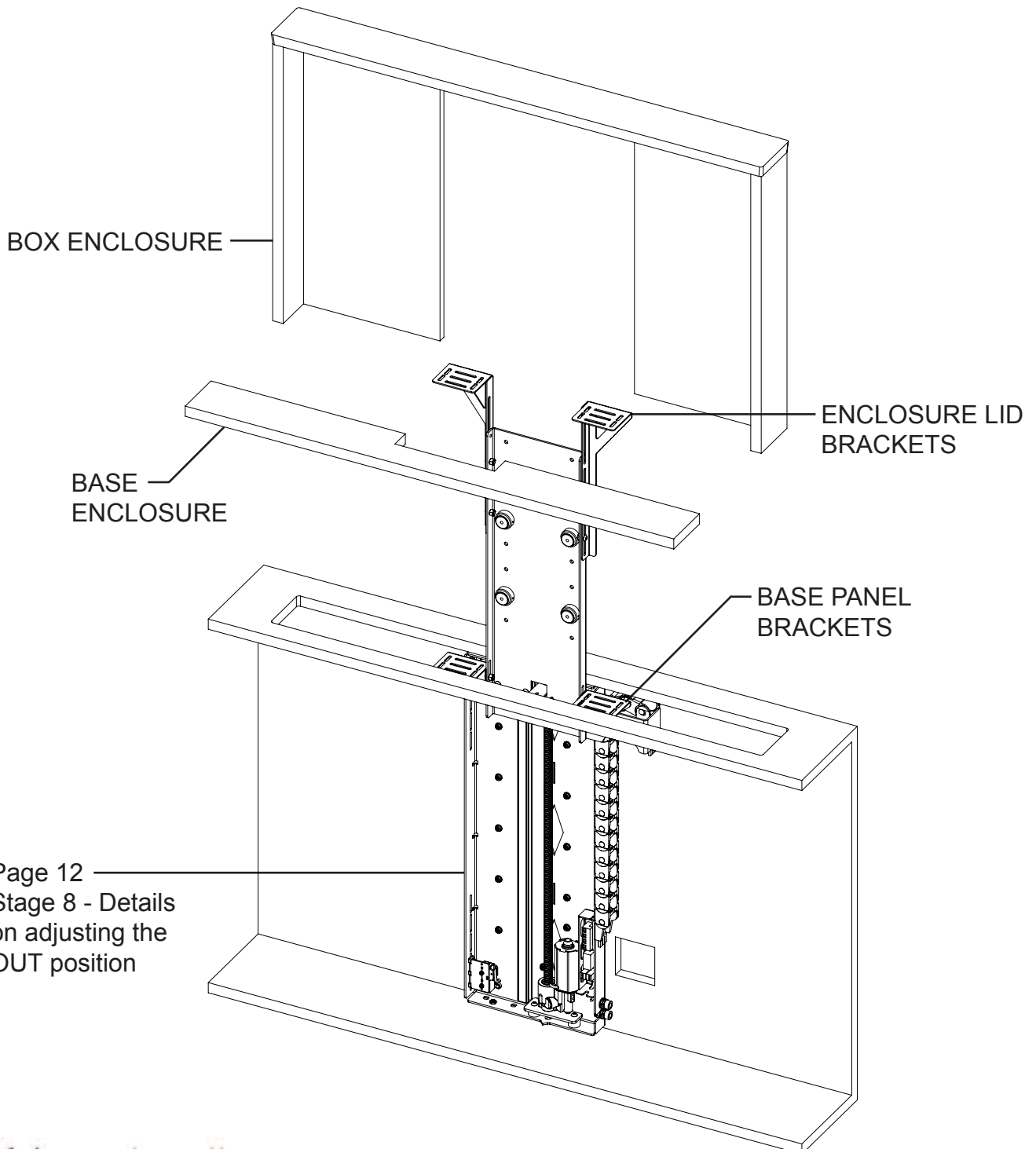

LSL BE - Lift System Light Box Enclosure



Attaching the Enclosure

With the mechanism still in the UP position fix the base panel to the BASE PANEL BRACKETS, adjust the height so the base panel sits flush to the cabinet top. Then adjust the ENCLOSURE LID BRACKETS to the correct height to support the cabinet lid and enclosure.

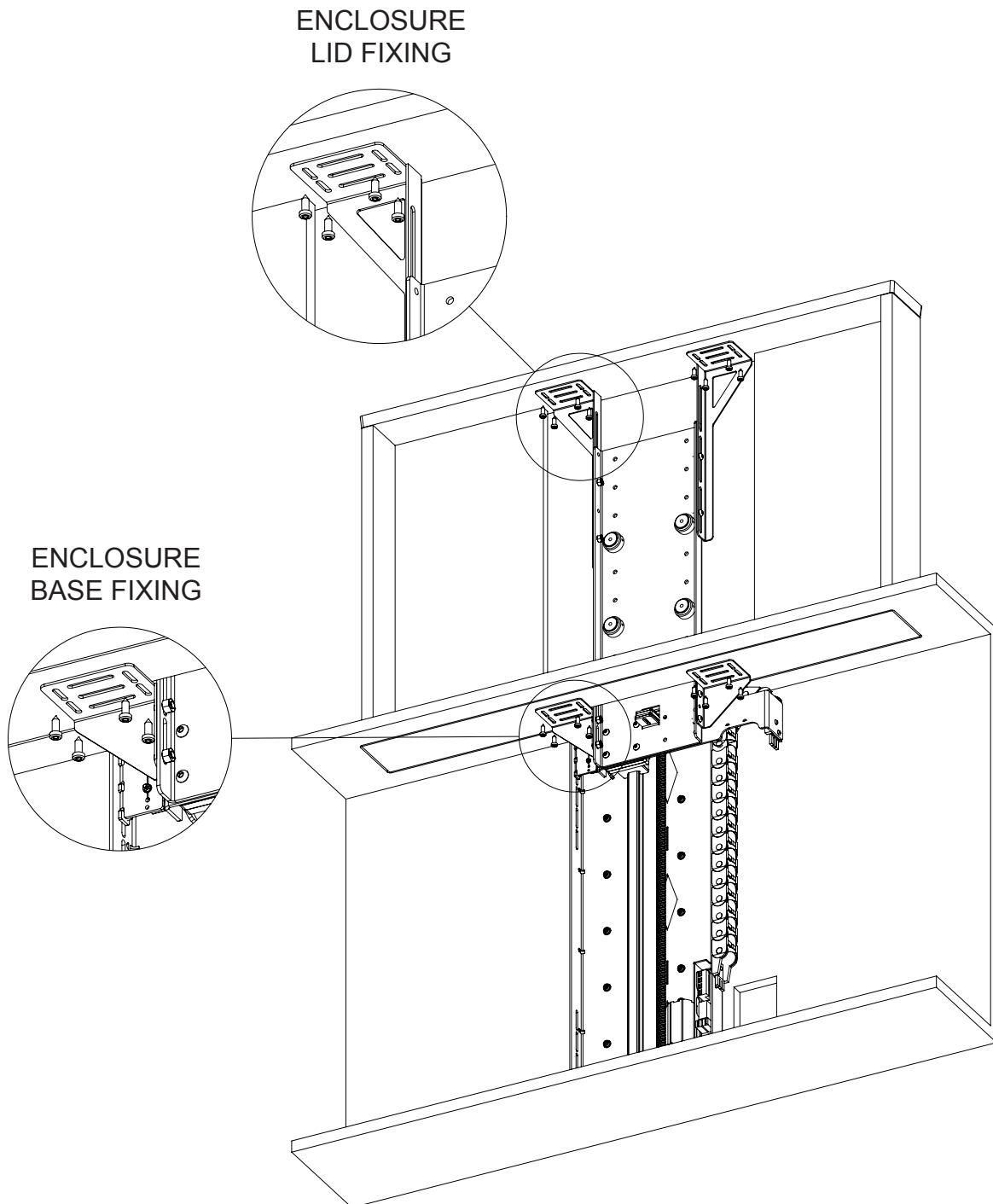

LSL BE - Lift System Light Box Enclosure



Routing Cables & Screen Mount Plate Fixing

Once the ENCLOSURE is fixed to the mechanism thread the screen and power cables through the cable management chain and then through the lifting beam shown with the orange dotted line.

KH MOUNT UPRIGHT

SCREEN MOUNT PLATE

Hook the SCREEN MOUNT PLATE on to the KH UPRIGHT over the TOGGLES and secure using the LOCKING LEVER.

LSL BE - Lift System Light Box Enclosure



Screen & Box Enclosure Mounting

Slide the screen into the enclosure and fix to the SCREEN MOUNT PLATE. A good tip is to use a packer under the screen and remove once fixed and secure.

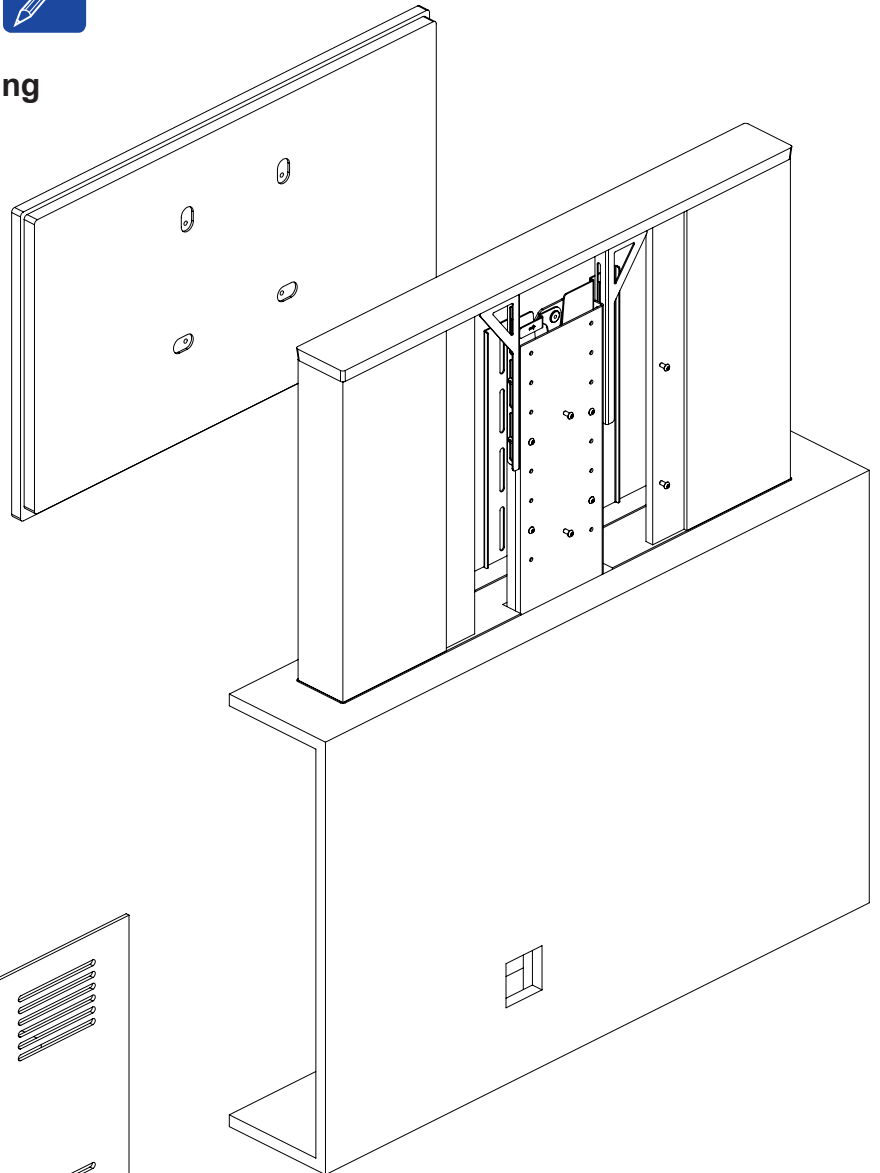

Finally offer the box enclosure back panel and fix to the sides. This back panel needs to be removable to take the screen off.

LSL BE - Lift System Light Box Enclosure



Switch Adjustments

You can adjust the IN and OUT position of the lifting beam. Detail 1 shows how to adjust the OUT position and detail 2 shows how to adjust the IN position. The IR sensor can be located anywhere outside of the cabinet.

1 - The top switch can't be adjusted when the mechanism is in the OUT position, because the switch is active. Lower the mechanism and press STOP after about 100mm [4"]. Then adjust the OUT switch plate by loosening the bolts and sliding the plate.

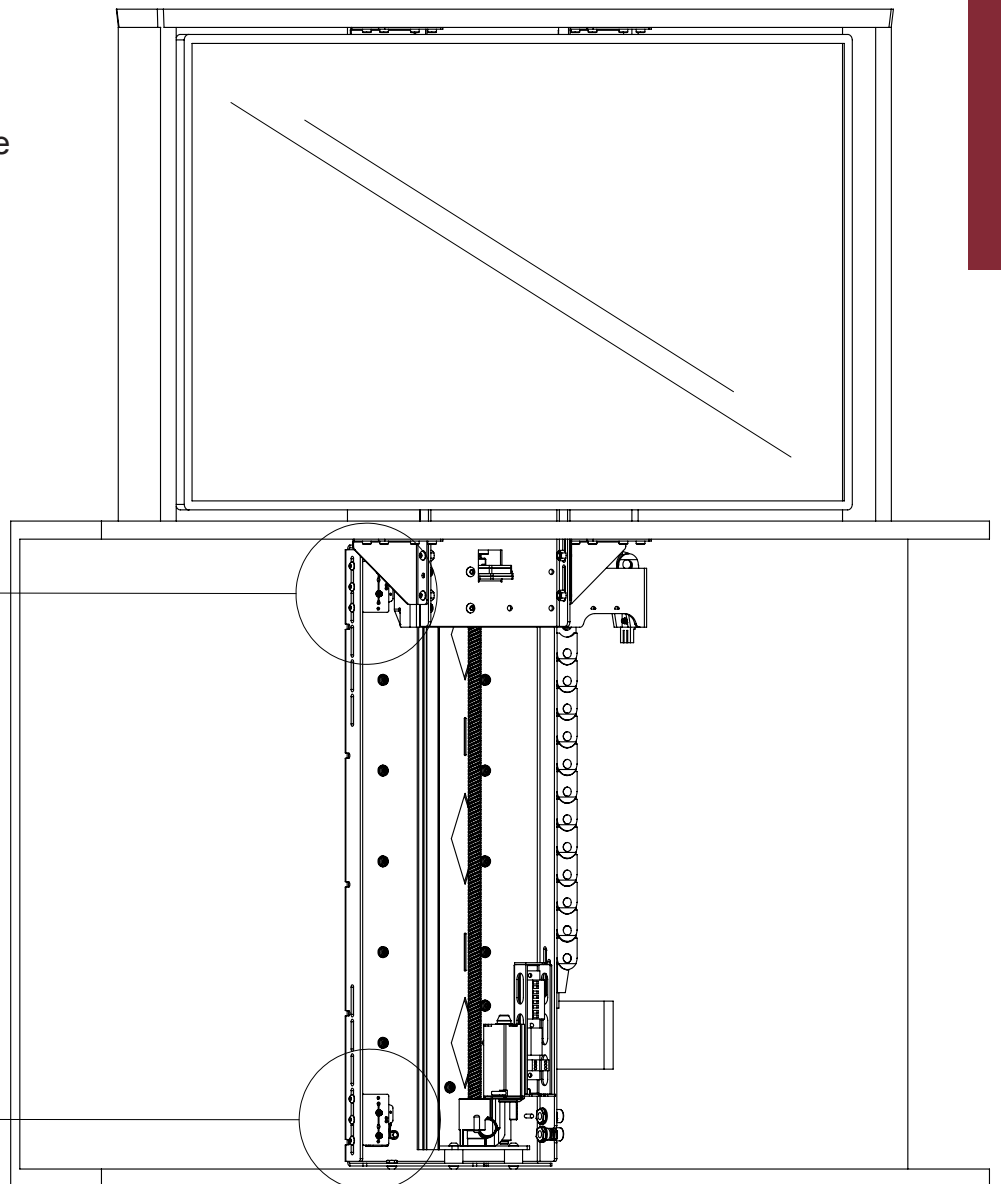
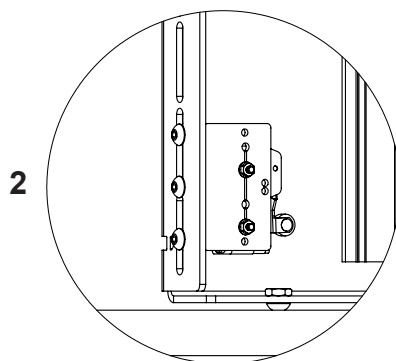
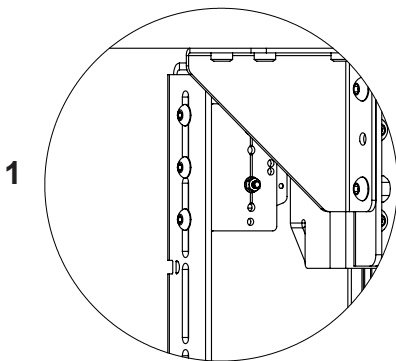

2 - Bottom switch can be adjusted by repeating the first procedure.

LSL BE - Lift System Light Box Enclosure



Contact Closure

- Use an RJ45 connector in the CCI socket on the control box to operate via contact closure

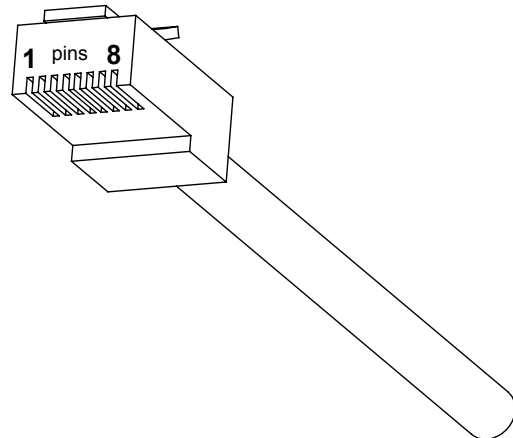

PIN	DESCRIPTION	ACTION	WIRE / CABLE		CONTACT CLOSURE LED INDICATOR
			568A	568B	
1	12V SUPPLY	12V SUPPLY - CURRENT LIMITED	W/G	W/O	
2	12V LATCH	When 12V attached, device will go OUT. When 12V removed, device will go IN.	G	O	
3	GROUND	GROUND	W/O	W/G	
4		PIN 4 NOT USED	BL	BL	
5	DEVICE LATCH	Short to GROUND (pin 3), device will go OUT, remove short device will go IN.	W/BL	W/BL	LED 4
6	DEVICE STOP	Momentary short to GROUND (pin 3), stops device in current position.	O	G	LED 3
7	DEVICE OUT	Momentary short to GROUND (pin 3), makes device go OUT.	W/BR	W/BR	LED 2
8	DEVICE IN	Momentary short to GROUND (pin 3), makes device go IN.	BR	BR	LED 1

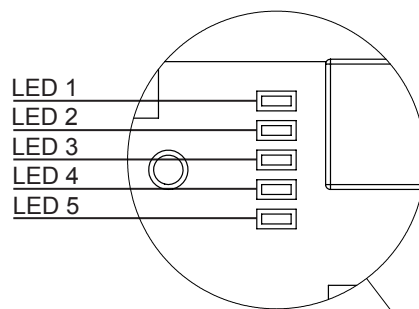

NOTE:
Earlier versions of the control board may not have these contact closure LED indicators.

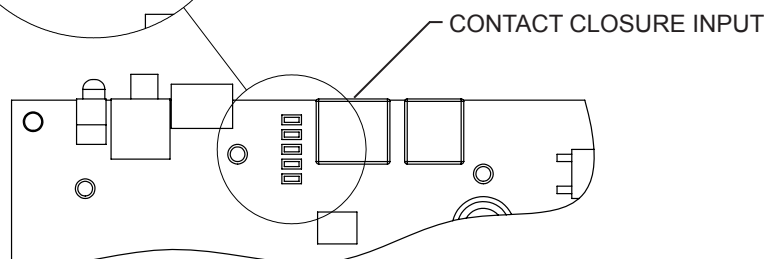

LSL BE - Lift System Light Box Enclosure



RS232

- Use an RJ25 connector in the socket marked RS232 on the control box to operate using RS232

Pin 1: RX
Pin 6 : TX
Pin 3 & 4: GROUND

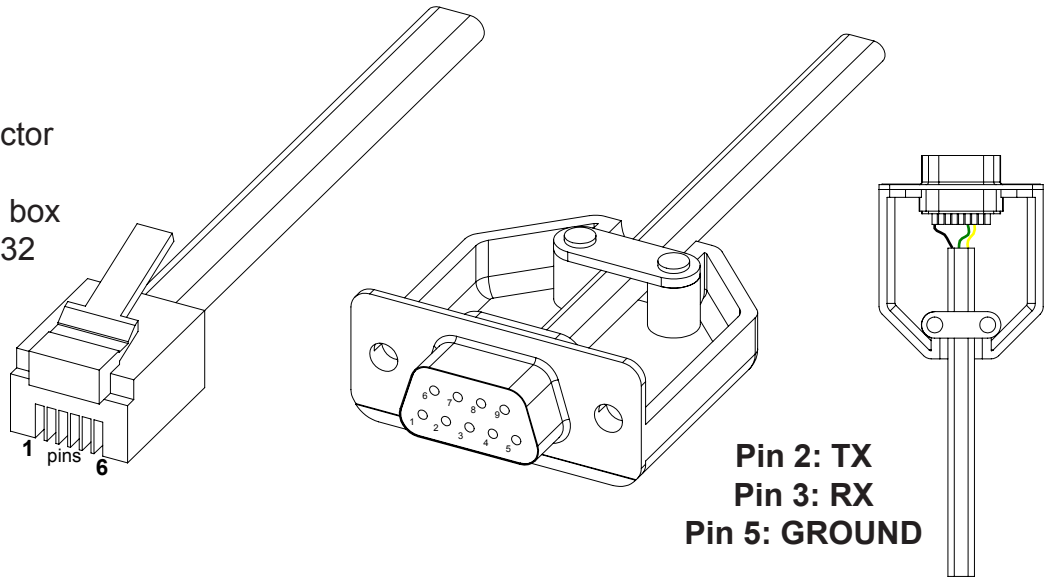

Pin 2: TX
Pin 3: RX
Pin 5: GROUND

Details

Baud rate: 9600
Stop bit: 1
Parity: None
Databits: 8

RJ25		9 PIN D
PIN 1: RX	TO	PIN 2: TX
PIN 6: TX	TO	PIN 3: RX
PIN 3: GROUND	TO	PIN 5: GROUND
PIN 4: GROUND	TO	PIN 5: GROUND



IMPORTANT

Ensure protocol is entered exactly as written, including Carriage Return (Enter / ASCII 13).

Protocol	Action
fa_in Carriage Return (Enter ←↵)	Device IN
fa_out Carriage Return (Enter ←↵)	Device OUT
fa_stop Carriage Return (Enter ←↵)	Device STOP (At any position)

Connection Locations

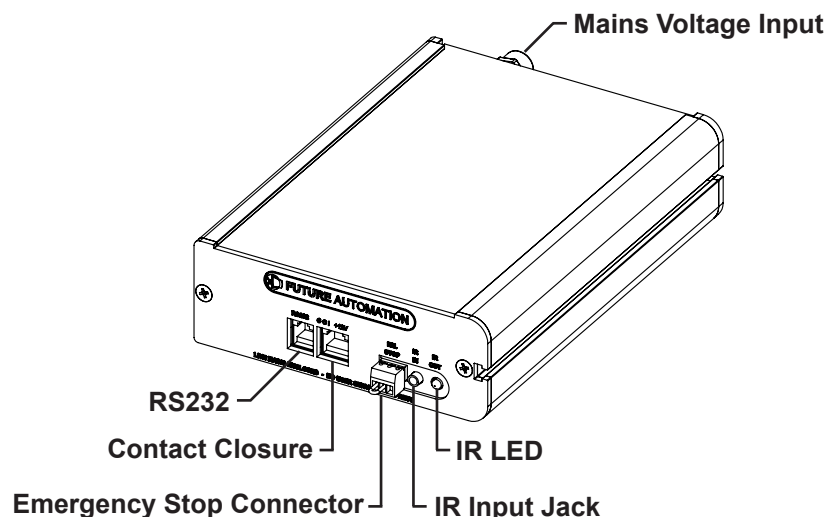

LSL BE - Lift System Light Box Enclosure



Operation buttons for the IR remote

In - Brings the mechanism inside the cabinet

Out - Brings the mechanism out of the cabinet facing forward

Stop - Will stop the operation at any position

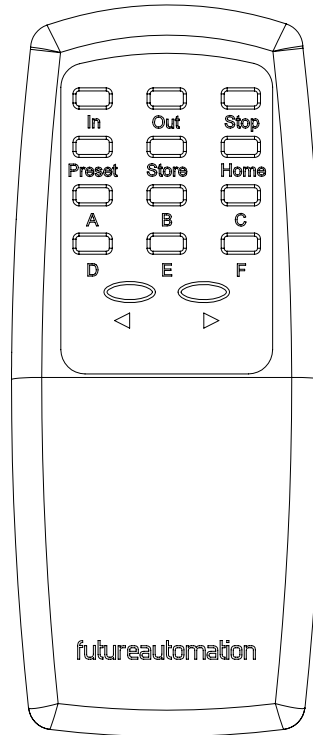

Note

Only buttons indicated are functional with the product. Any button pressed when in motion will stop the mechanism.

Replacing batteries



Future Automation IR Remote Controller needs x2 AAA batteries which are provided within the packaging

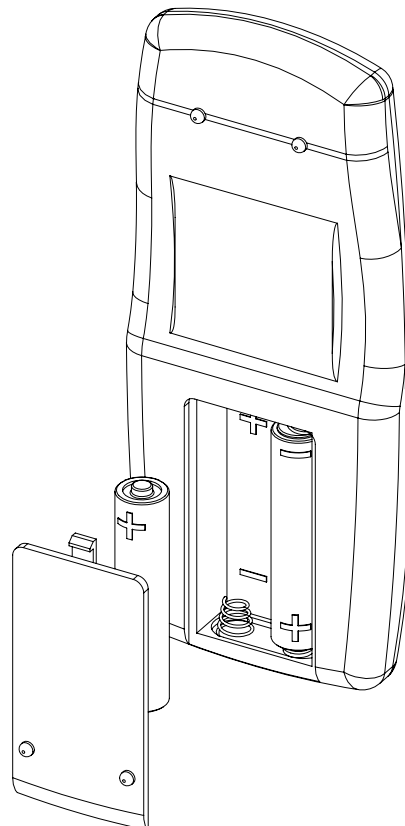

LSL BE - Lift System Light Box Enclosure



Lift System Light Box Enclosure - Trouble shooting guide

Lift System Light Box Enclosure - Trouble shooting

For information on our products please refer to our web site -
www.futureautomation.co.uk
or for questions on installations and our product range please
phone us on - **+44(0) 1438 833577** and ask for our technical
support department

LSL BE - Lift System Light Box Enclosure



Technical Overview

A general technical overview of the LSL BE lift mechanism range

	LSL BE RANGE		
Product Size Range	LSL BE 1	LSL BE 2	LSL BE 3
Product Dimensions	Width - 394mm [15.5"]	Width - 394mm [15.5"]	Width - 394mm [15.5"]
	Height - 580mm [22.8"]	Height - 694mm [27.3"]	Height - 769mm [30.3"]
	Depth - 117mm [4.6"]	Depth - 117mm [4.6"]	Depth - 117mm [4.6"]
Weight Approx	15Kg [33.0lb]	17Kg [37.5lb]	19Kg [41.9lb]
Power Consumption	250W - 500W	250W - 500W	250W - 500W
Power Consumption On Standby	100mA	100mA	100mA
Lifting Capacity	25Kg [55lb]	25Kg [55lb]	25Kg [55lb]
Lifting Capacity Marine	16Kg [35lb]	16Kg [35lb]	16Kg [35lb]
Standard Screen Mount Colour	Black	Black	Black
Max Television Size	Height - 410mm [16.1"]	Height - 524mm [20.6"]	Height - 599mm [23.6"]
Control	IR Remote, RF Remote, Contact Closure & RS232	IR Remote, RF Remote, Contact Closure & RS232	IR Remote, RF Remote, Contact Closure & RS232
Power Supply	240V or 110V	240V or 110V	240V or 110V
Control Of 3rd Party Product	Yes	Yes	Yes
Output Power Supply	Yes (12V)	Yes (12V)	Yes (12V)
Control Box Size (W,D,H)	150x210x52mm [5.9x8.3x2.0"]	150x210x52mm [5.9x8.3x2.0"]	150x210x52mm [5.9x8.3x2.0"]
Shipping Details	600x300x1000mm [23.6x11.8x39.4"]	600x300x1000mm [23.6x11.8x39.4"]	600x300x1000mm [23.6x11.8x39.4"]
Dimensions Approx (W,D,H)			
Weight Approx	20Kg [44.1lb]	22Kg [48.5lb]	24Kg [52.9lb]

LSL BE - Lift System Light Box Enclosure



Notes...



Future Automation

Unit 2 Kimpton Enterprise Park
Claggy Road
Kimpton
Hertfordshire
SG4 8HP
United Kingdom

Tel: +44 (0) 1438 833 577

Fax: +44 (0) 1438 833 565

Email: info@futureautomation.co.uk

www.futureautomation.co.uk