



## DESIGN HIGHLIGHTS

- Quiet smooth action at approximately 40mm [1.6] per second
- Full cable management
- Wide range of mounting options
- 24V DC motor. Suitable for direct DC supply
- Marine suitable robust beam

## OPTIONS

- Box Enclosure
- Box Enclosure with Swivel
- Push Up Flap
- Custom screen back cover
- Heavy duty option

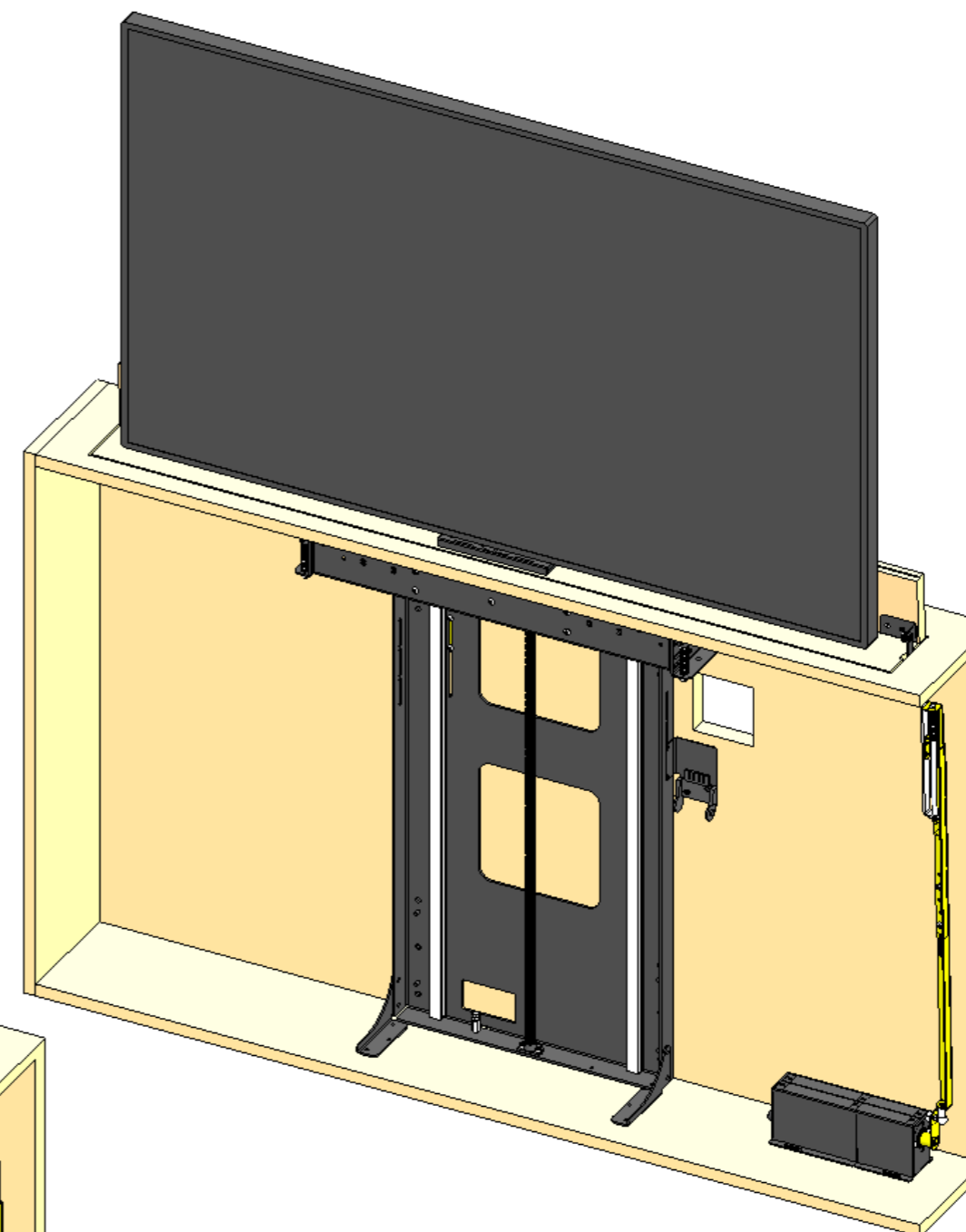
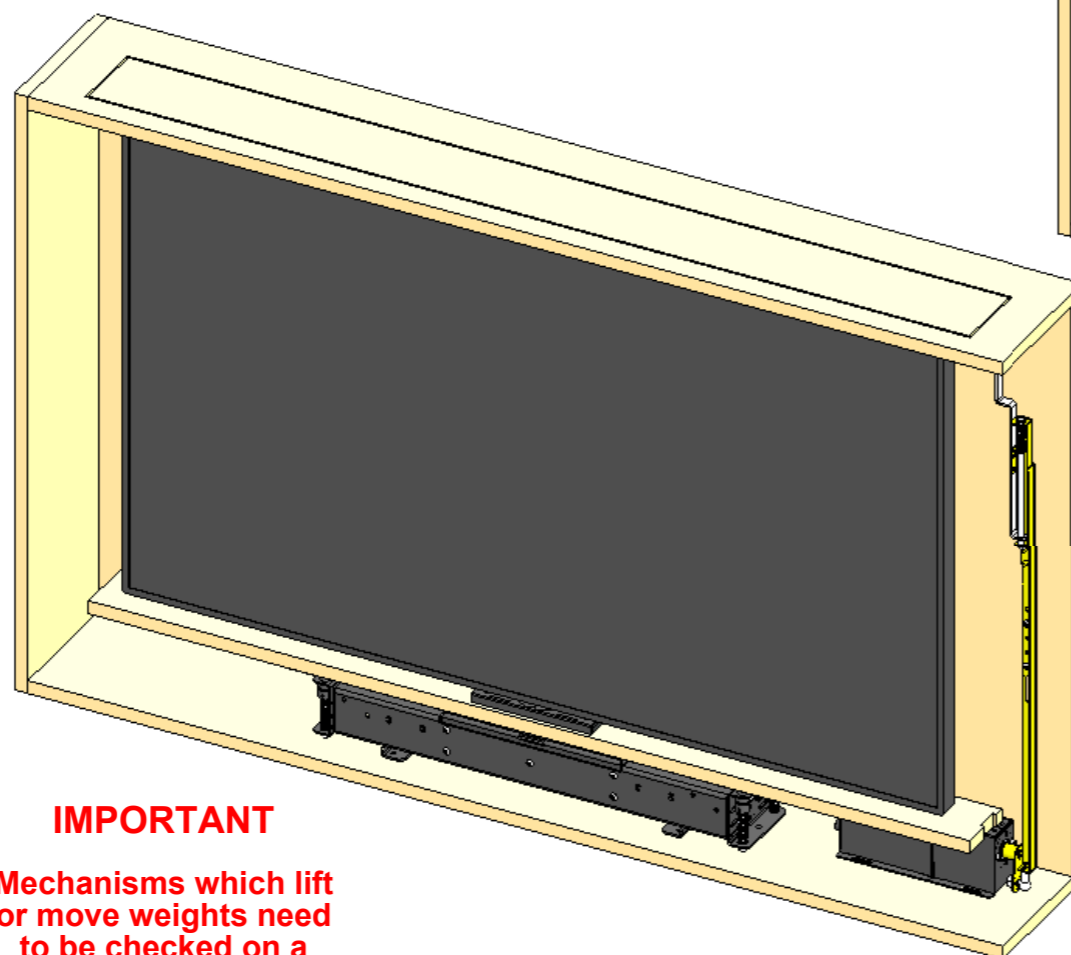

## FUNCTION

An electric mechanism to lift a flat screen television. Suitable for marine use. Shown here for use with an Electric Flap Actuator.

## SUITABILITY

Suitable for a total lifting weight of 50Kg [110lbs] or 30Kg [66lbs] in a marine environment.

Maximum screen height 805mm [31.7]

Lift mechanisms to suit different screen heights are available

## SPECIFYING

Check screen mounting details and request a suitable mount plate

## CONTROL

Supplied with basic infrared remote. Can be learnt by many learning remotes.

Also has switch control and RS232 so can be operated by relays, switches, Crestron / AMX or Lutron systems.

## WARNING

It is the responsibility of the installer to warn all potential end users of the dangers of interfering with mechanisms during operation

## IMPORTANT

Mechanisms which lift or move weights need to be checked on a yearly basis for any damage which may result in an accident

## Design Highlights

A space efficient and robust lifting mechanism, suitable for use in marine environments.

A robust 24V DC motor with a purpose made lead screw enables a quiet and smooth lifting action at approximately 40mm [1.6] per second.

High precision linear guideways ensure stability and durability of the beam to prevent any unwanted movement of the screen.

Adjustable UP and DOWN positions allow for a precise final setup within the cabinet.

The safety switched base reduces the risk of damage to the mechanism or injury to the user by cutting power to the motor when there is an obstruction between the cabinet and base panel.

Full cable management protects all screen and power cables from damage and is easily accessible for future changes to the AV setup.

A wide range of mounting options are available to suit different screens and speaker arrangements.

The Electric Flap Actuator mechanism eliminates the need for a lid or box to be mounted around the screen.

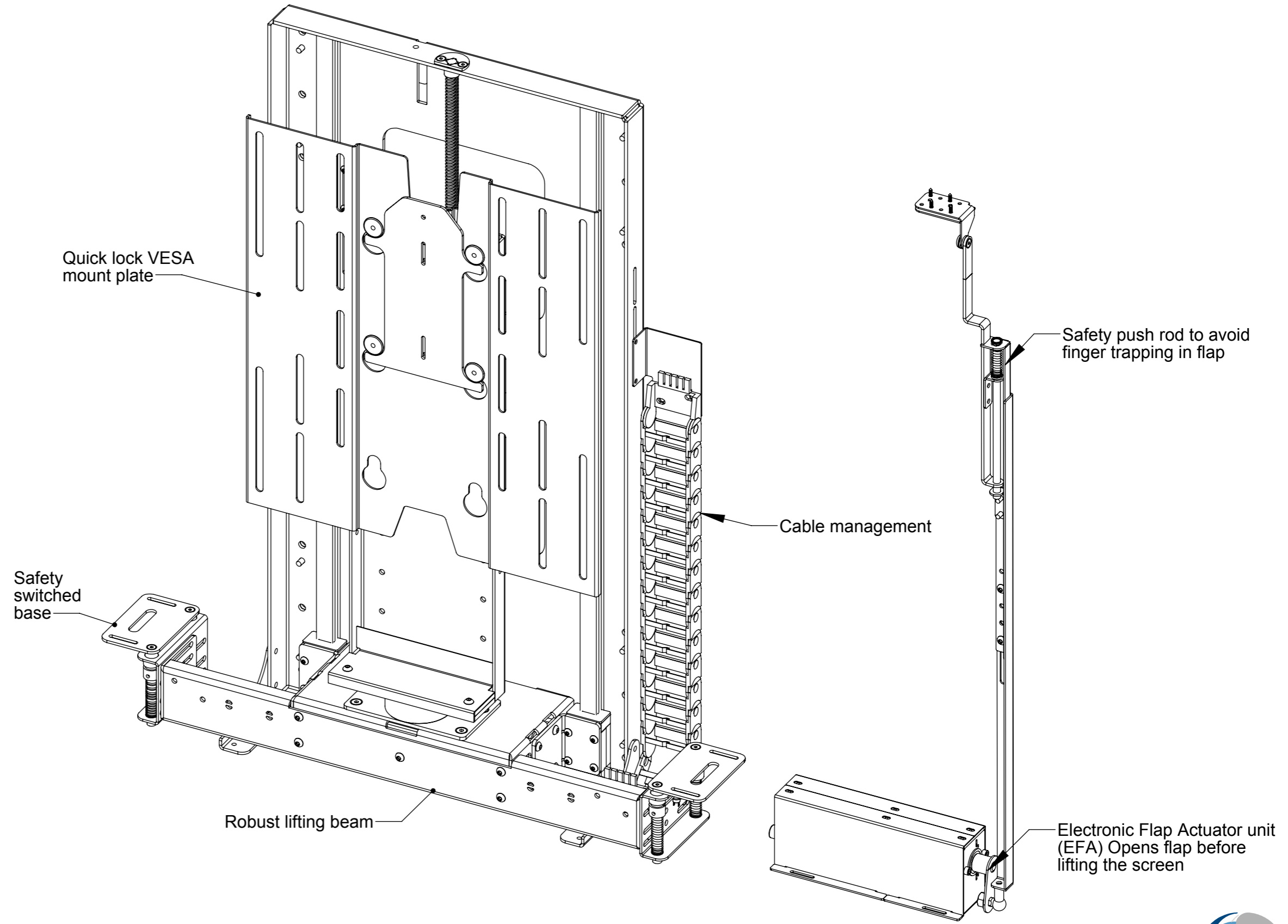

## Cable Routing

The LSM has an easily removable Mount Cover that cables from the screen can be routed underneath. Cables then travel through the centre of the Mount Boss and into the beam. Cables must be routed carefully to prevent any interference with the LSM beam as it operates.

Screen and Mechanism cables should be routed to a control box outside of the cabinet via an opening in the back of the cabinet or a conduit leading to the bottom.

- - - SCREEN CABLE
- - - MECHANISM CABLE
- - - POWER CABLE

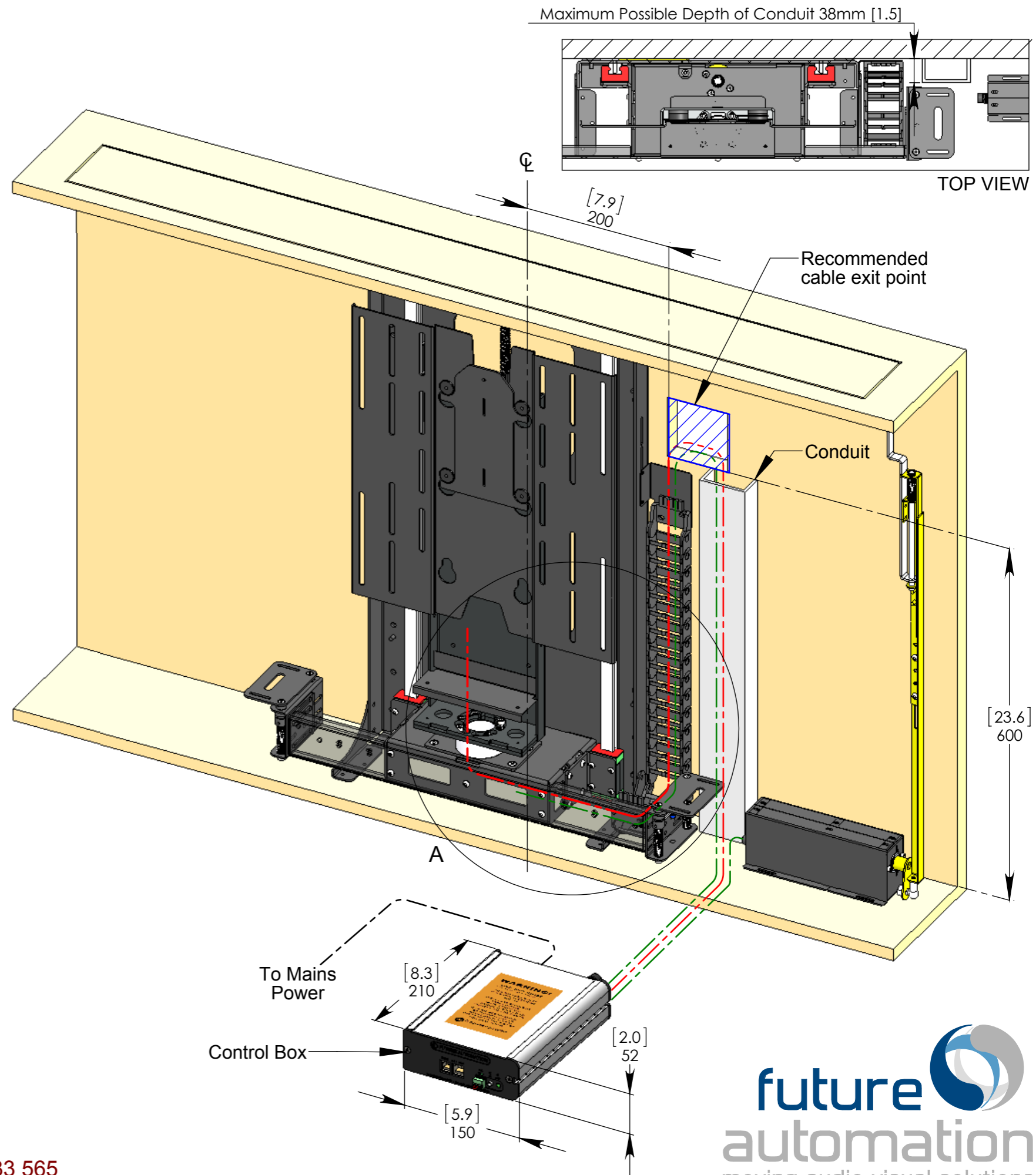
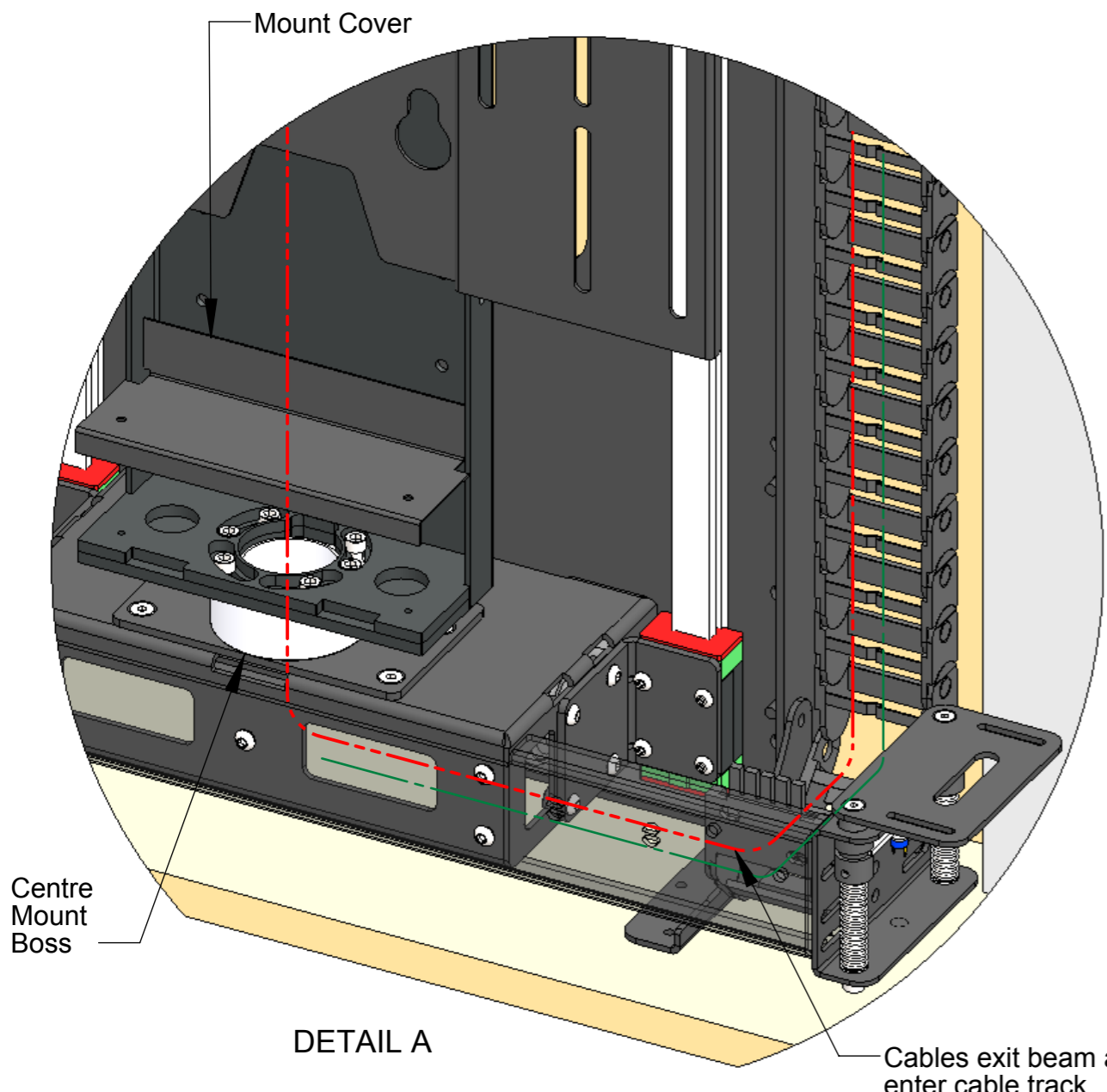

## Mechanism Up - In Cabinet

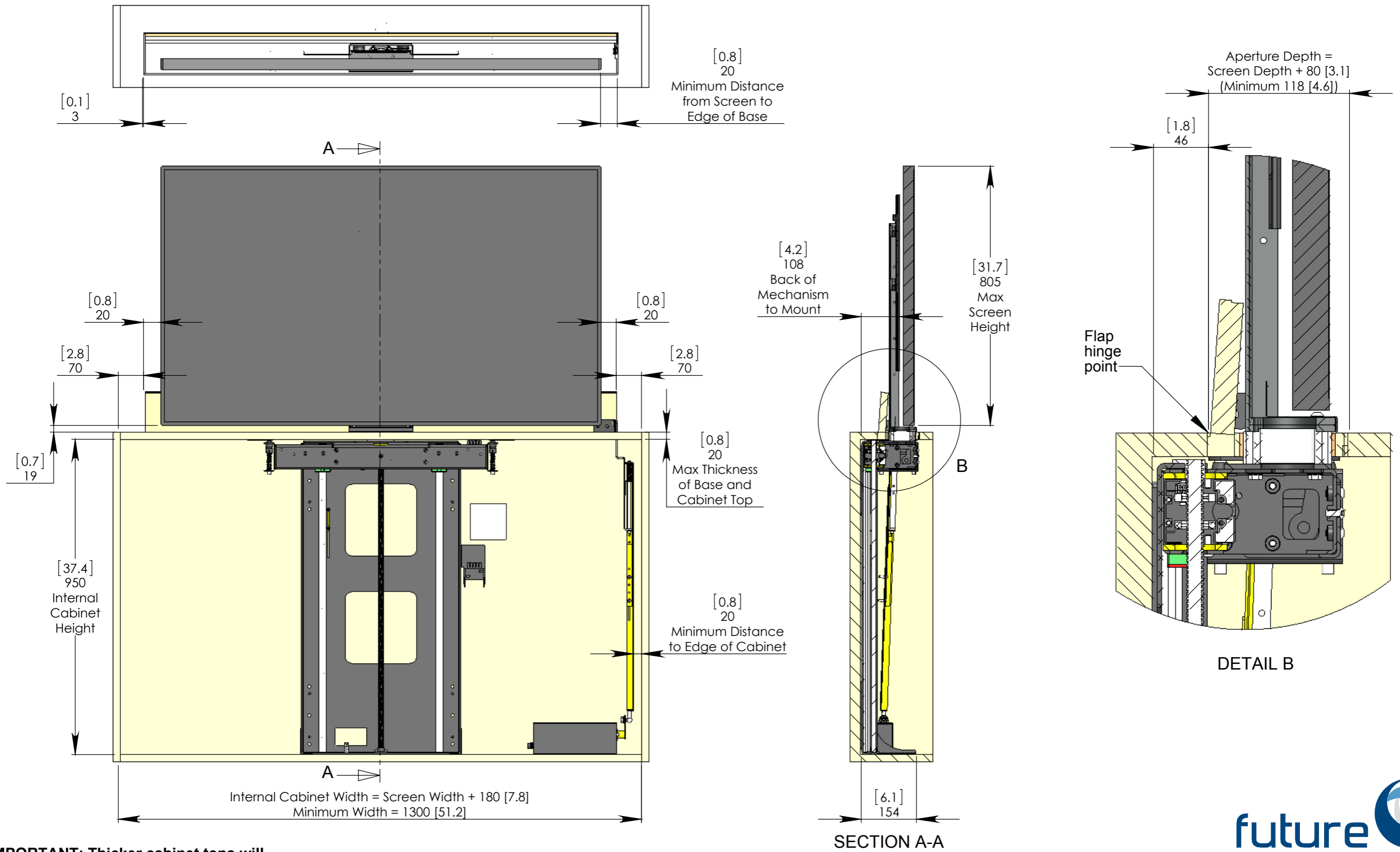

**IMPORTANT: Thicker cabinet tops will require a reduced maximum screen height**

## Mechanism Down - In Cabinet

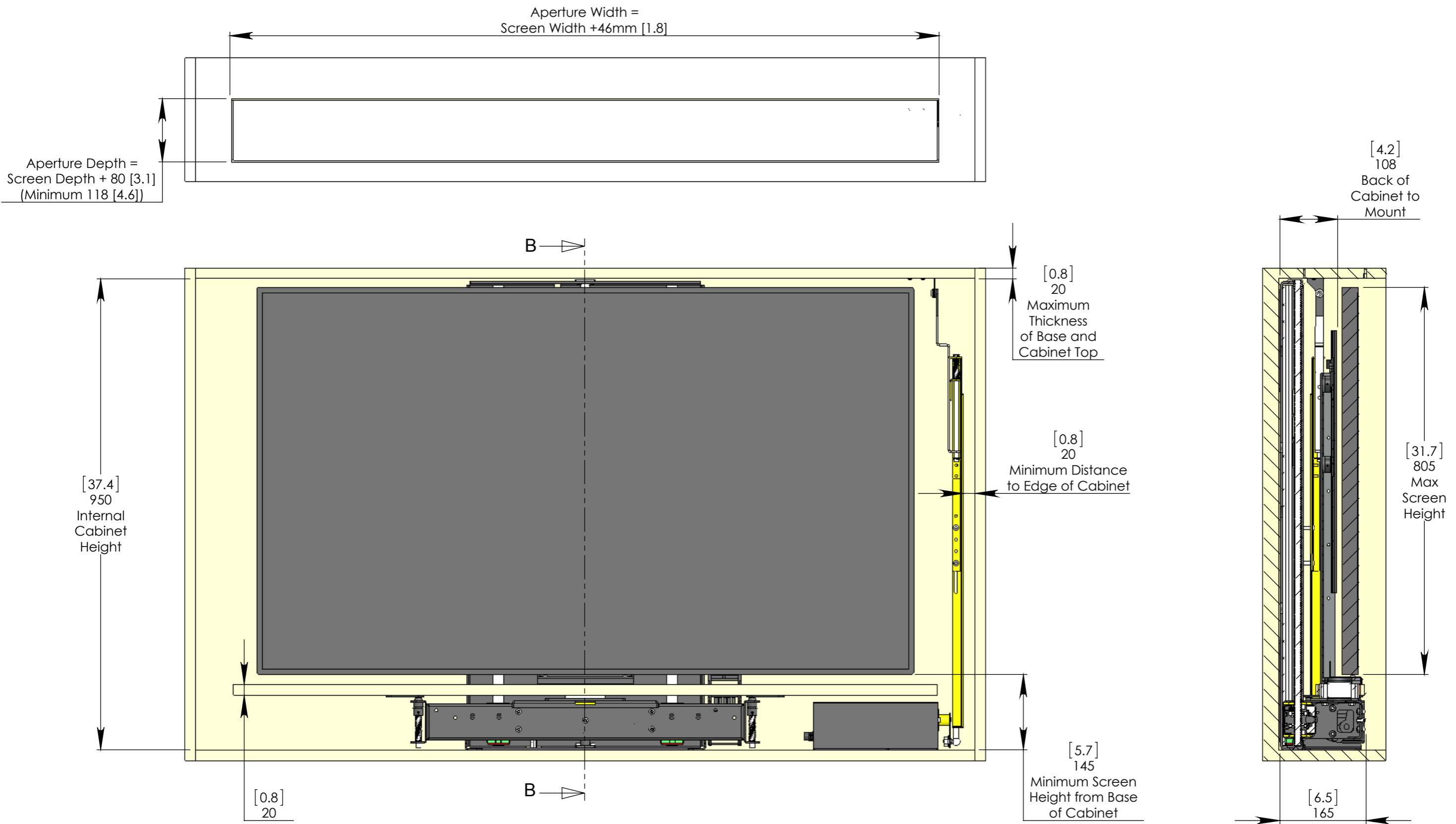

**IMPORTANT:** Thicker cabinet tops will require a reduced maximum screen height

## Base Panel and Flap Panel Details

Flap depth dimensions are based on a 3mm thick piano hinge  
 Required flap dimensions may vary dependant on the hinge used

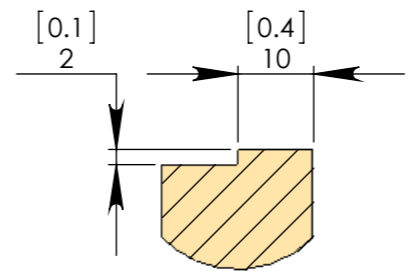

A step is required on the front of the flap to meet a step in the front edge of the cabinet aperture

**FLAP PANEL - BOTTOM VIEW**

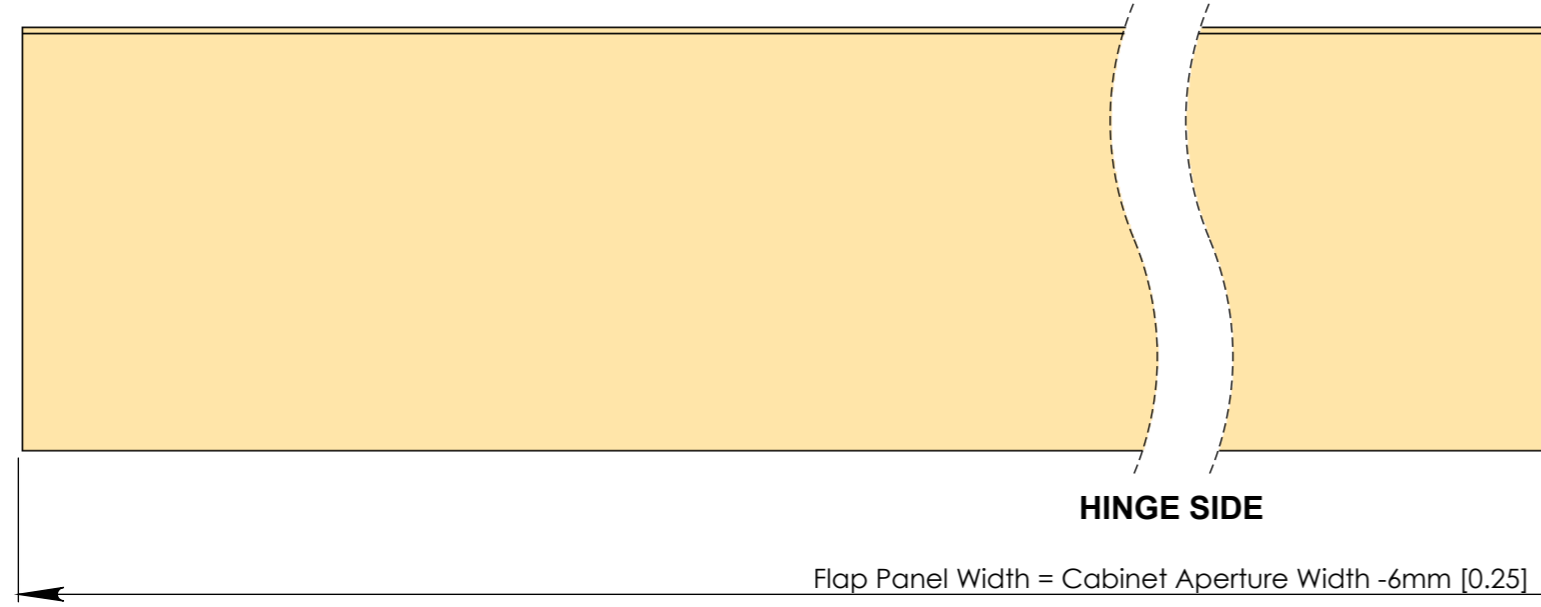

**DETAIL C**

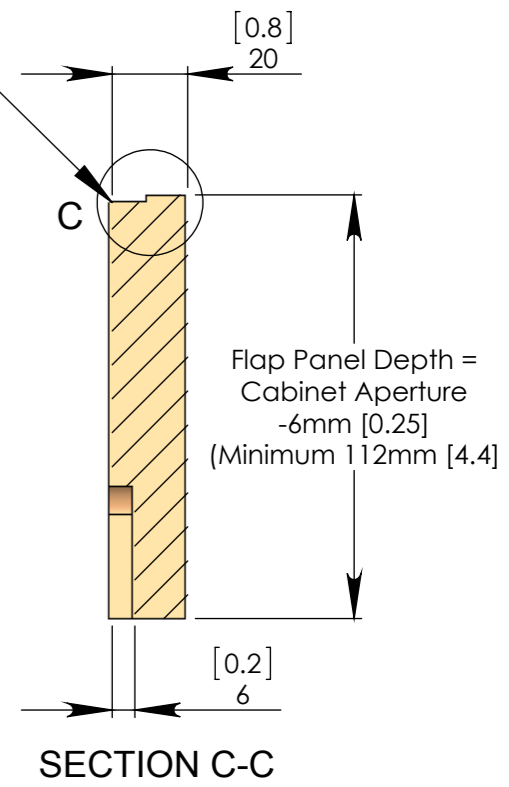

**BASE PANEL - TOP VIEW**

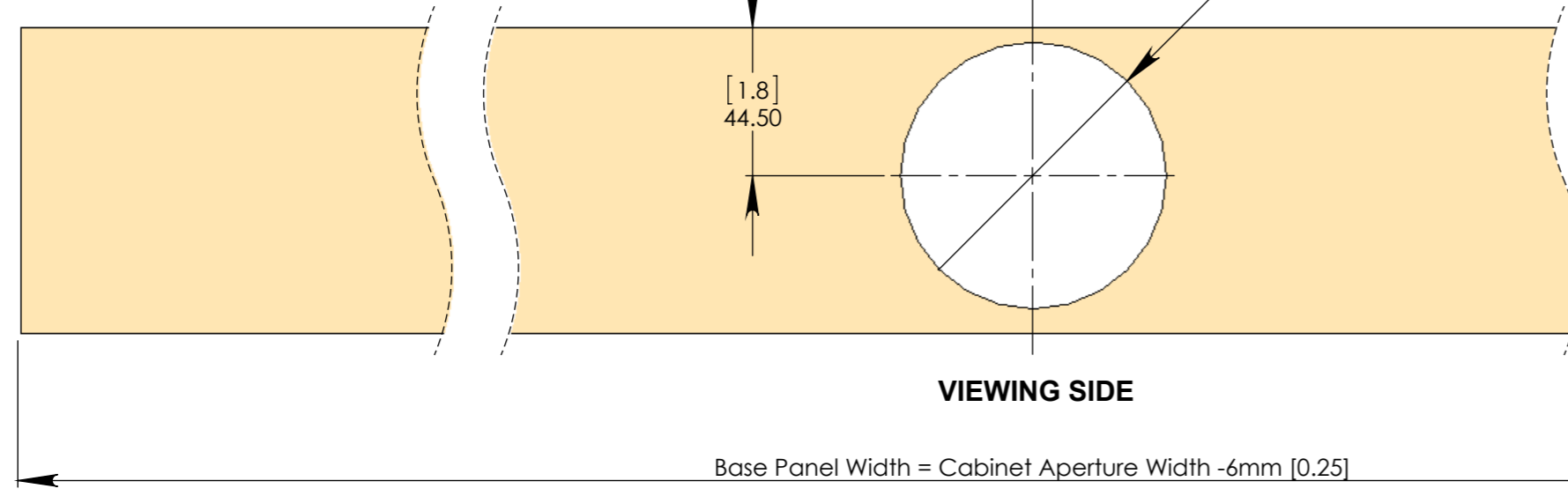

**Cut-out for EFA Push Rod**

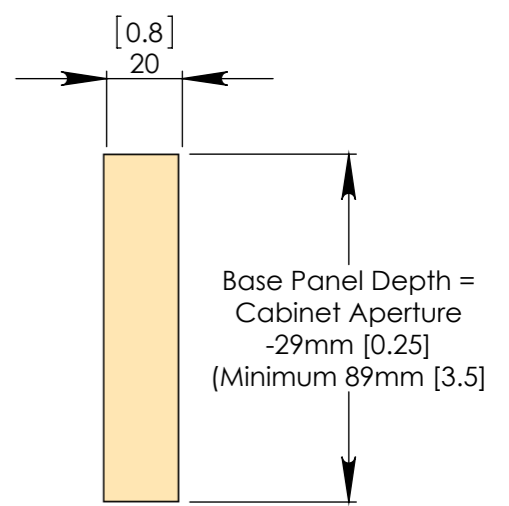
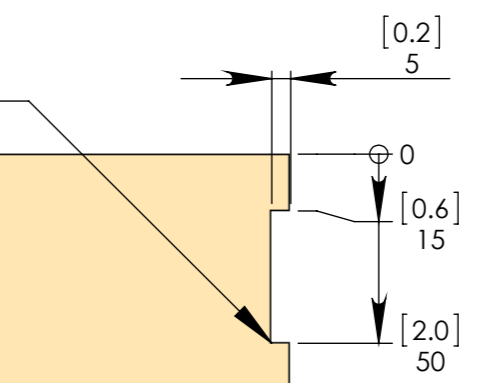

## Positioning the EFA to Accommodate Smaller Screens

A Base Panel of less than 1170mm [46.0] wide will cause the EFA to interfere with the LSM beam.

This can be avoided by orientating the EFA away from the LSM. It will however require more space for the EFA to be positioned to the side of the cabinet.

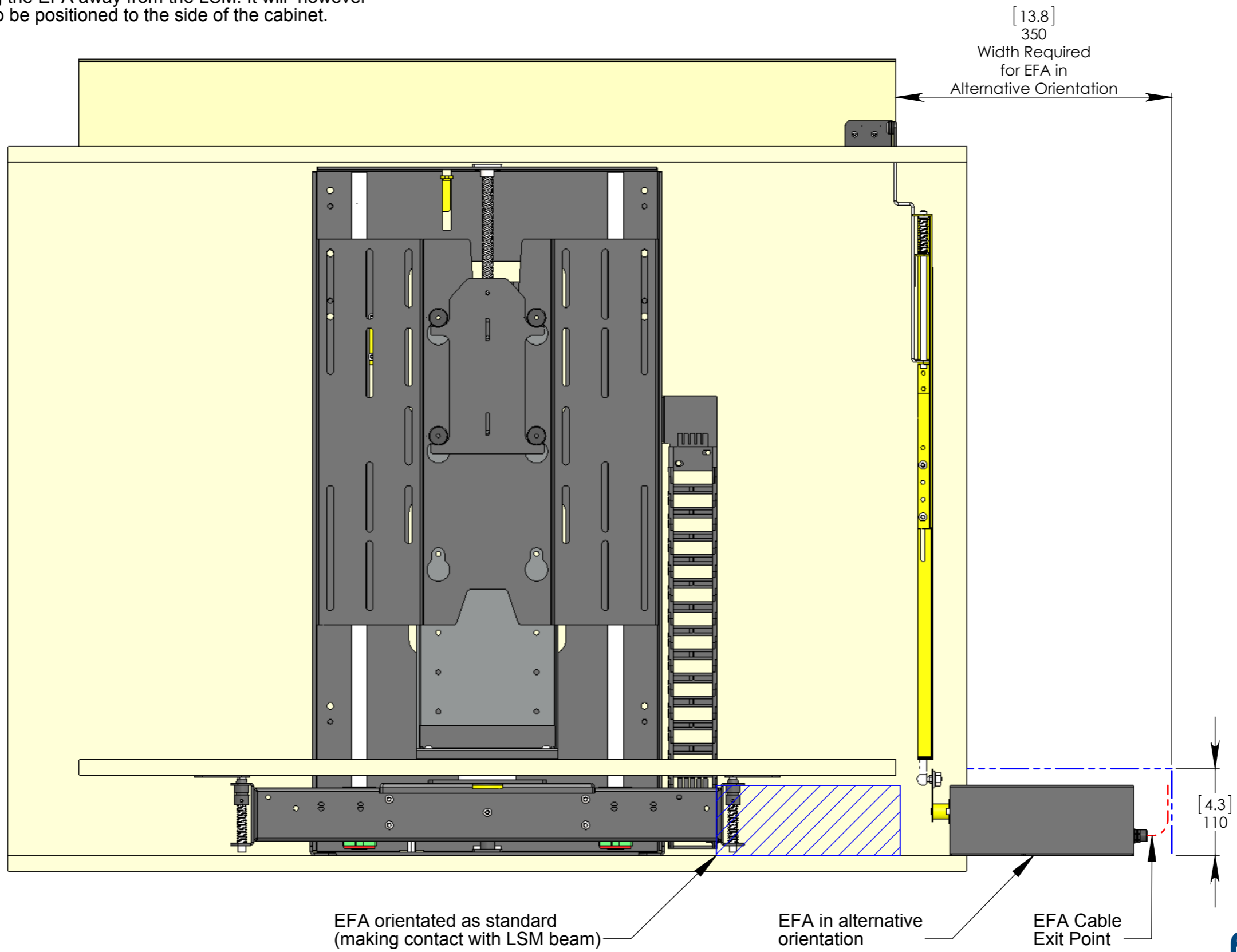

## Screen Mount Adjustability

A standard adjustable height VESA 400 mount is included. This is also compatible with VESA 300 and 200 mounting patterns

Separate VESA 300 and 200 mounts are available.

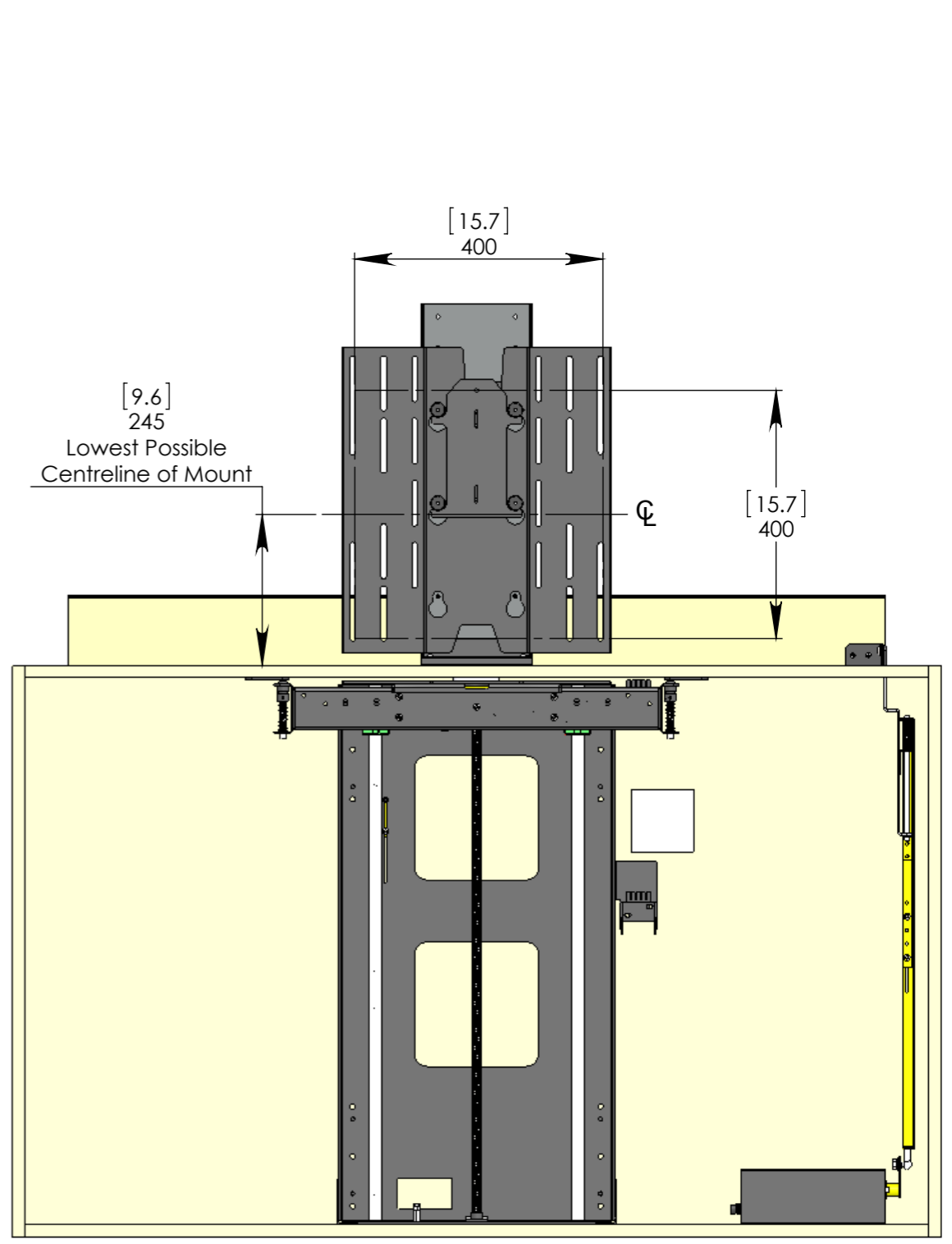
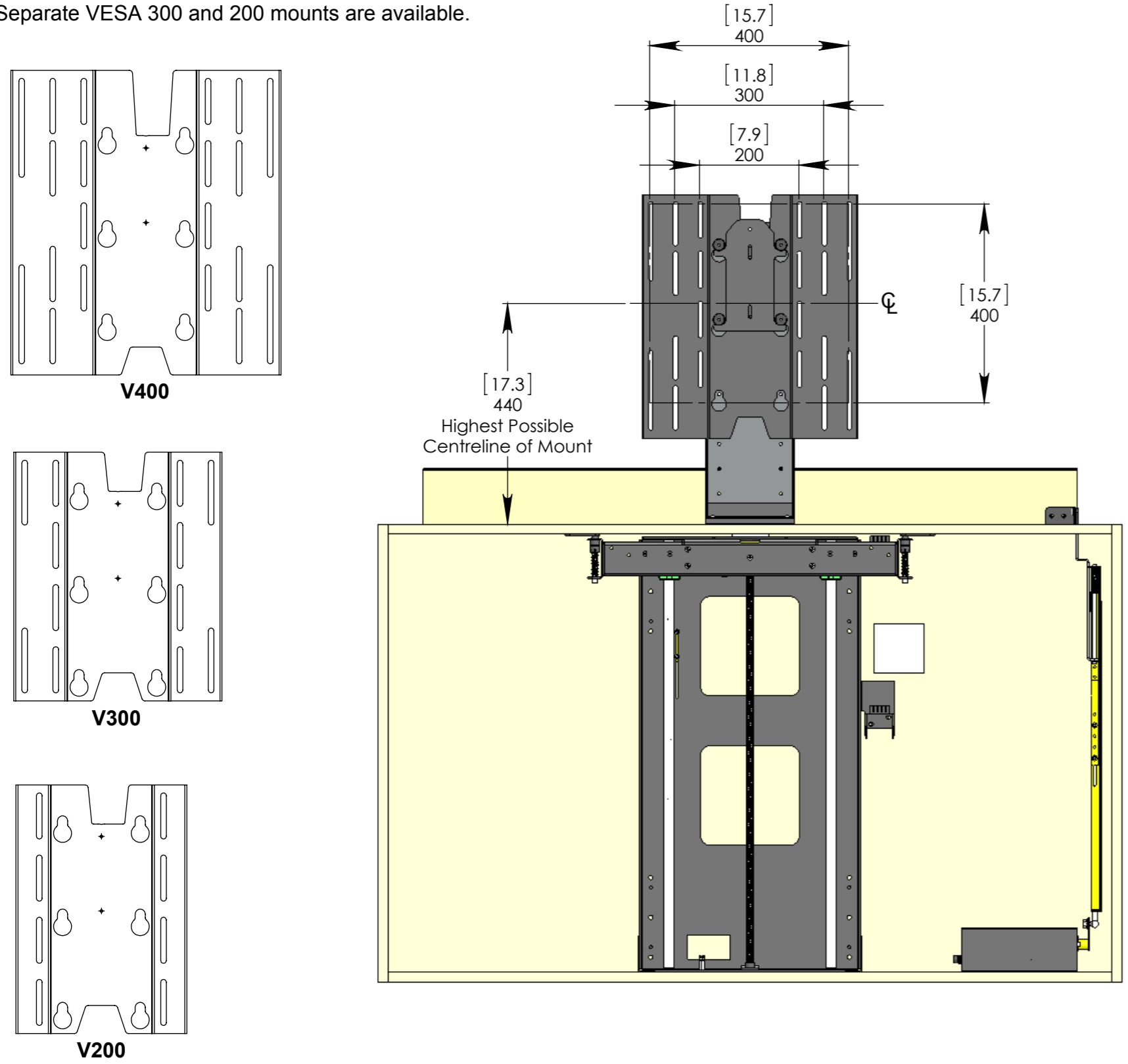



## Mechanism Installation Overview

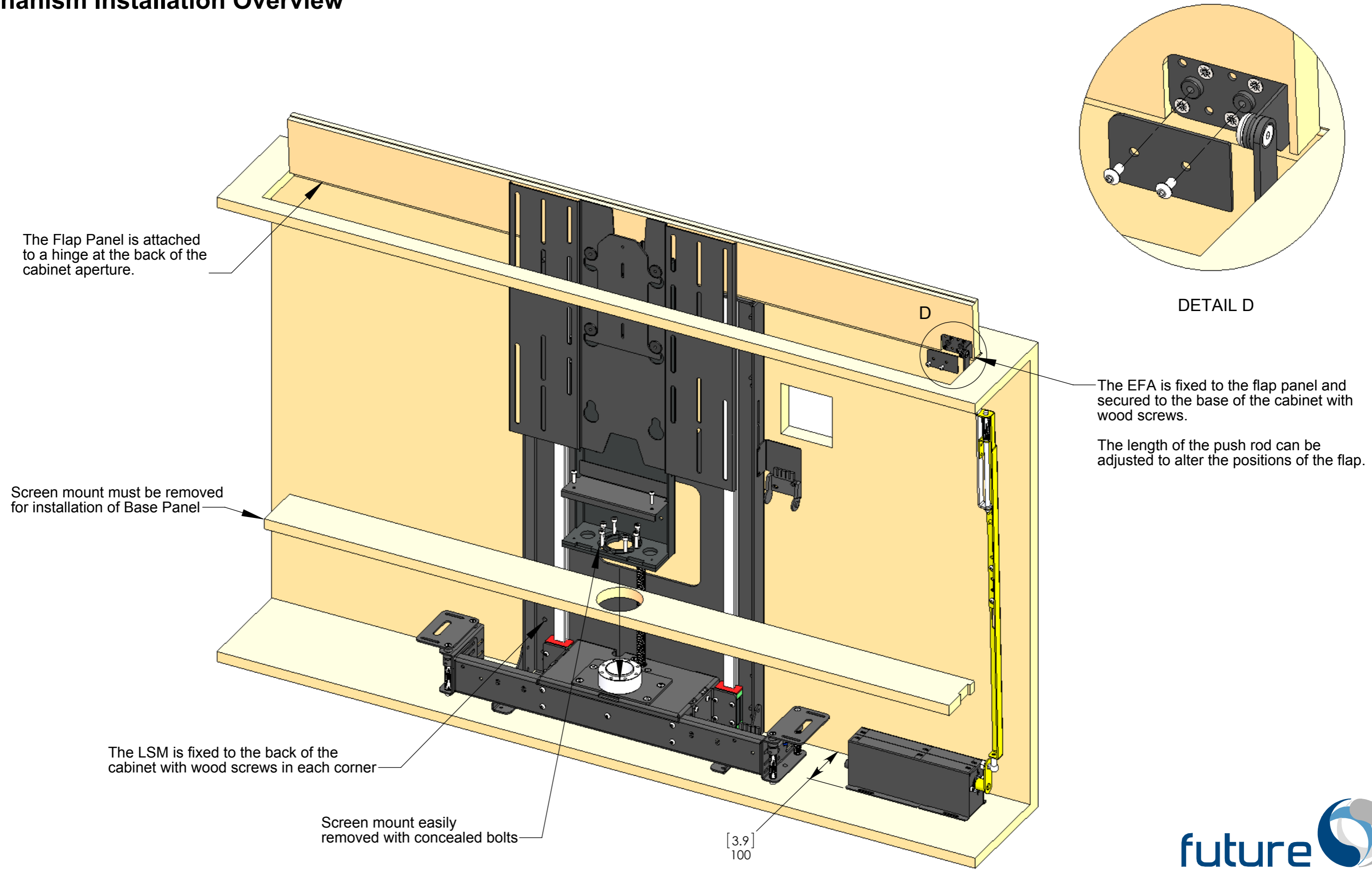

## Overall Mechanism Dimensions

### MECHANISM - UP POSITION

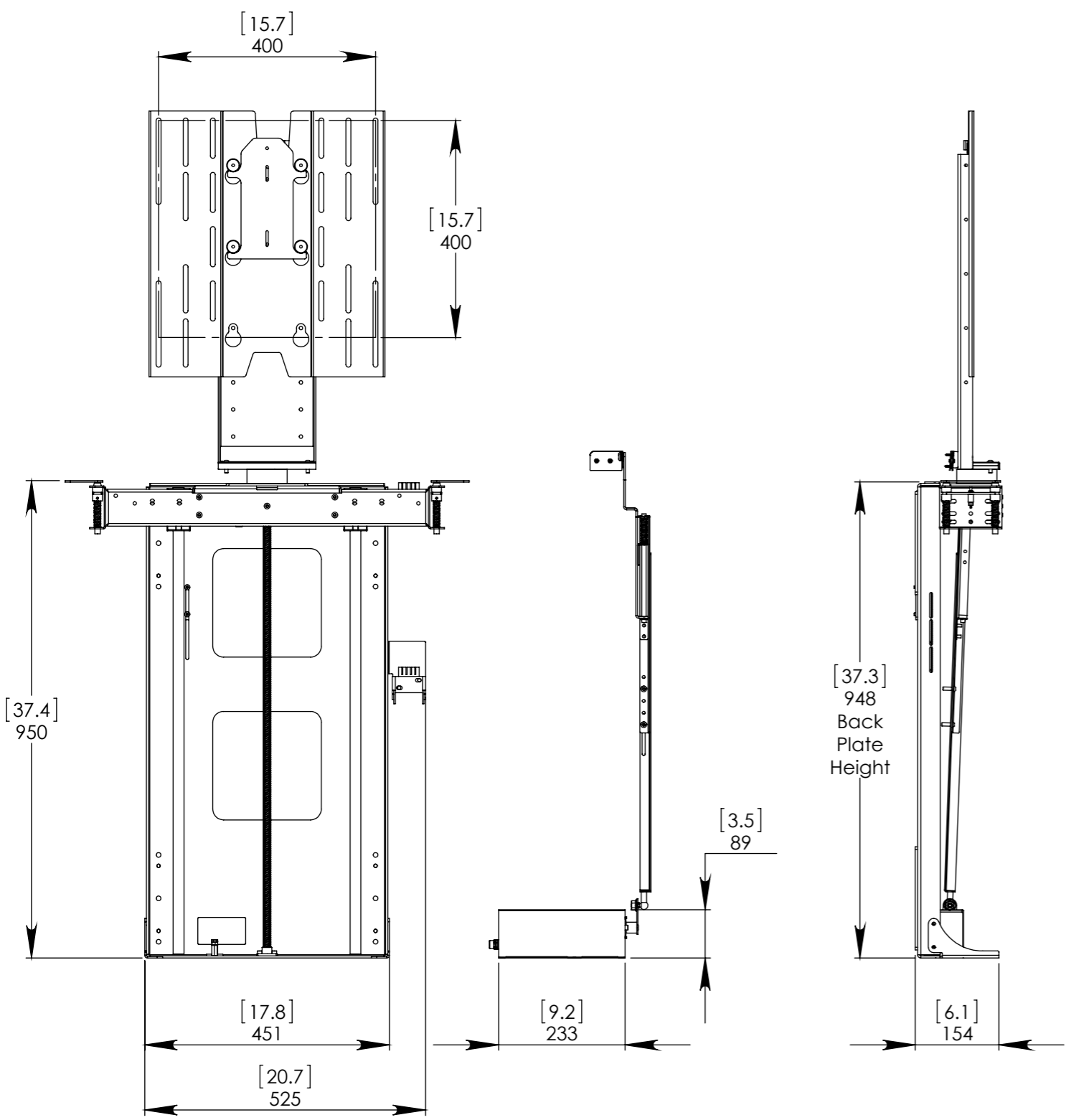

### MECHANISM - DOWN POSITION

