



DESIGN HIGHLIGHTS

- Quiet smooth action
- Full cable management
- Stylish look and finish
- Onboard electronics
- Wide range of mounting options

OPTIONS

- Clockwise and Counter-Clockwise swivelling mechanisms available
- Any RAL colour available

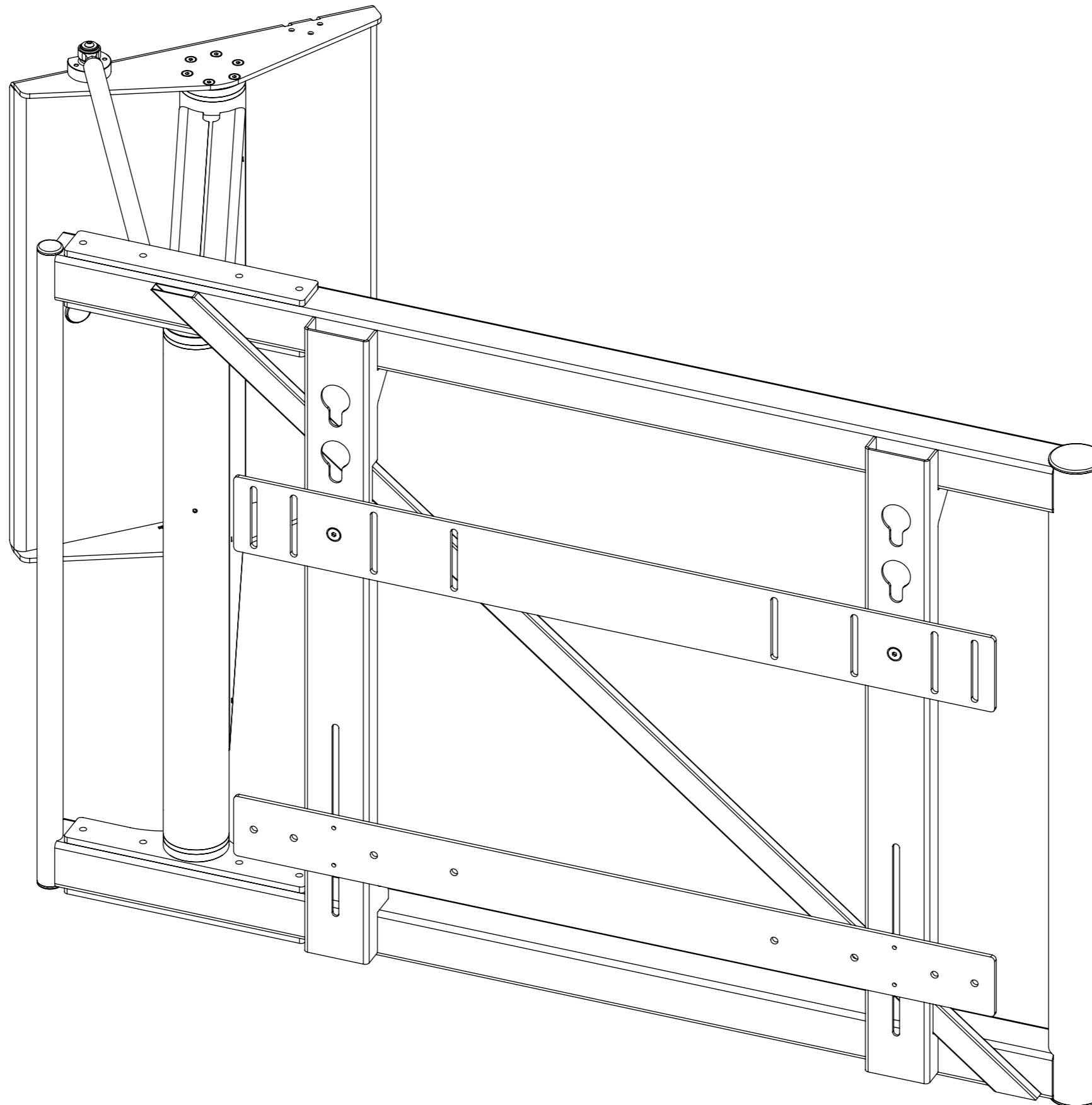

FUNCTION

A heavy duty electric wall bracket designed to rotate a screen away from a wall in one direction to an angle of up to 90°.

Intended for larger, heavier screens.

SUITABILITY

Suitable for screen sizes between 70" and 98" with a maximum weight of 125Kg [275lbs]

Maximum screen width
2220mm [87.5]

Minimum screen width
1350mm [53.2]

Minimum screen height
930mm [36.6]

It is possible to mount a screen larger than 98" on the HSE. However, this is likely to restrict the maximum viewing angle (see page 10).

The smaller PSE90 bracket is suitable for screen sizes between 37" and 65"

SPECIFYING

Confirm suitability of screen dimensions and weight.

Check angles for viewing and specify required direction of rotation.

Check screen mounting details.

Check wall makeup to decide on fixings to be used.

CONTROL

Supplied with basic infrared remote. Can be learnt by many learning remotes.

Also features switch control and RS232 so can be operated by relays, switches, Crestron / AMX or Lutron systems.

Design Highlights

An extremely robust structure provides a reliable and sturdy platform for a large screen to be rotated between multiple viewing angles.

A super quiet motion is achieved through careful selection of components and a design that minimises friction and wear.

A powerful motor and a high quality gearbox provide a smooth and consistent movement between viewing angles.

Up to 1143mm [45.0] of extension can be achieved from the wall to the screen centre.

Favourite viewing positions can be programmed via the remote control.

A highly adjustable screen mounting system allows for a wide range of large screens to be specified.

Magnetic wall covers provide a simple method of hiding all wall fixings.

Power and signal cables for the screen and mechanism can be concealed within the bracket.

Removable arm covers allow for easy installation and routing of cables, whilst giving a neat and tidy finish.

The mechanism is available with either a clockwise or counter-clockwise rotation.

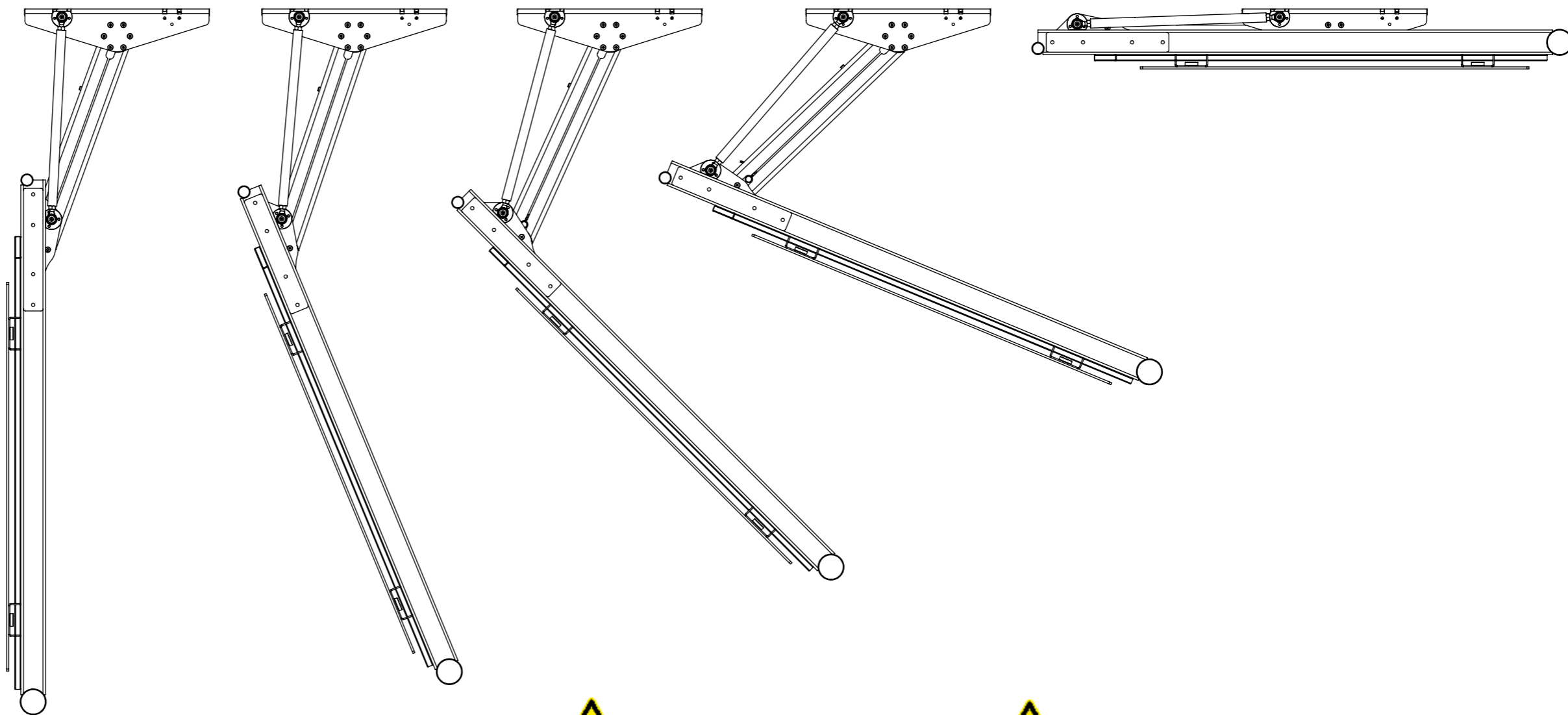

Be sure to specify the required direction of rotation

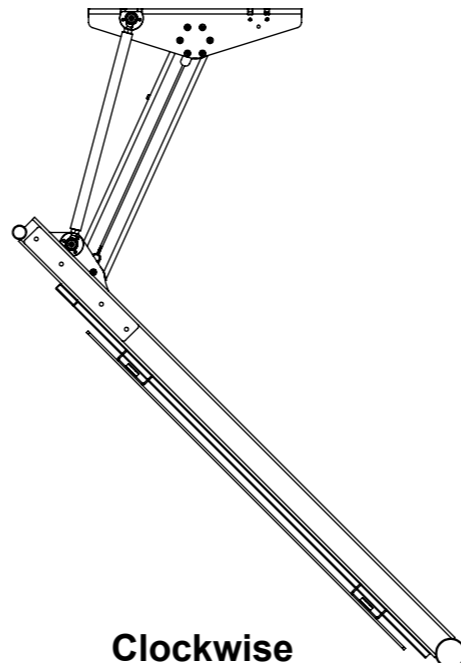

Clockwise

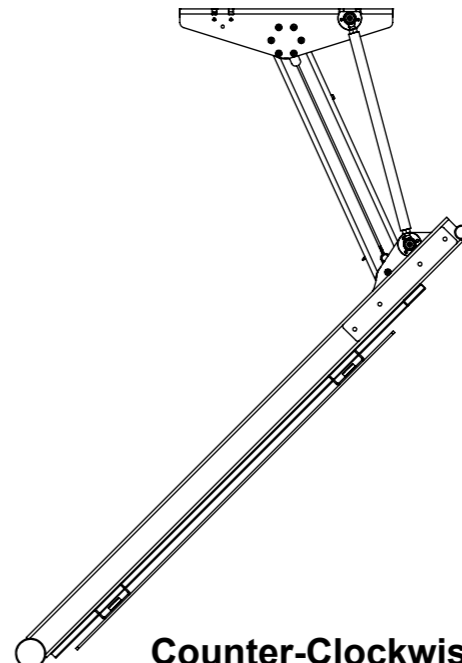

Counter-Clockwise

Cable Routing

The covers on the primary arm are removable. This allows screen cables to be routed through the mechanism with ease.

Screen and Power cables exit from the bottom of the wall mount and can be routed into an opening in the wall behind or a conduit leading to the floor.

- SCREEN CABLE
- MECHANISM POWER & CONTROL CABLES

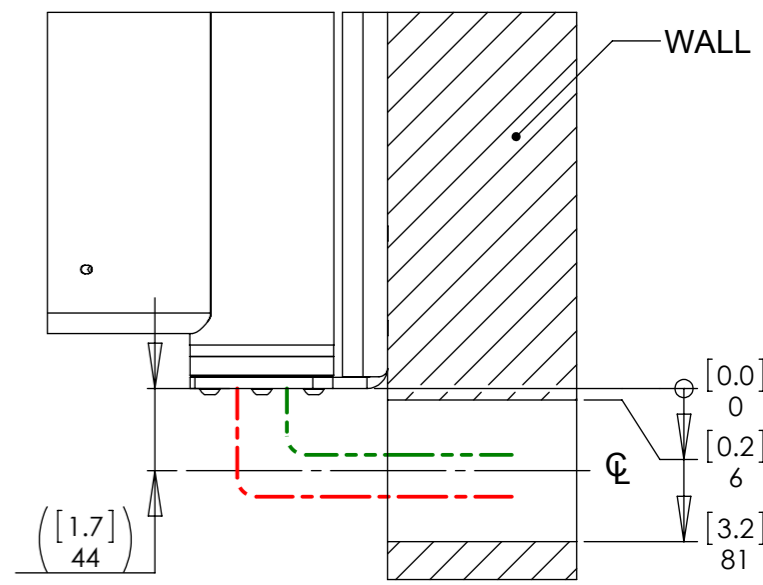
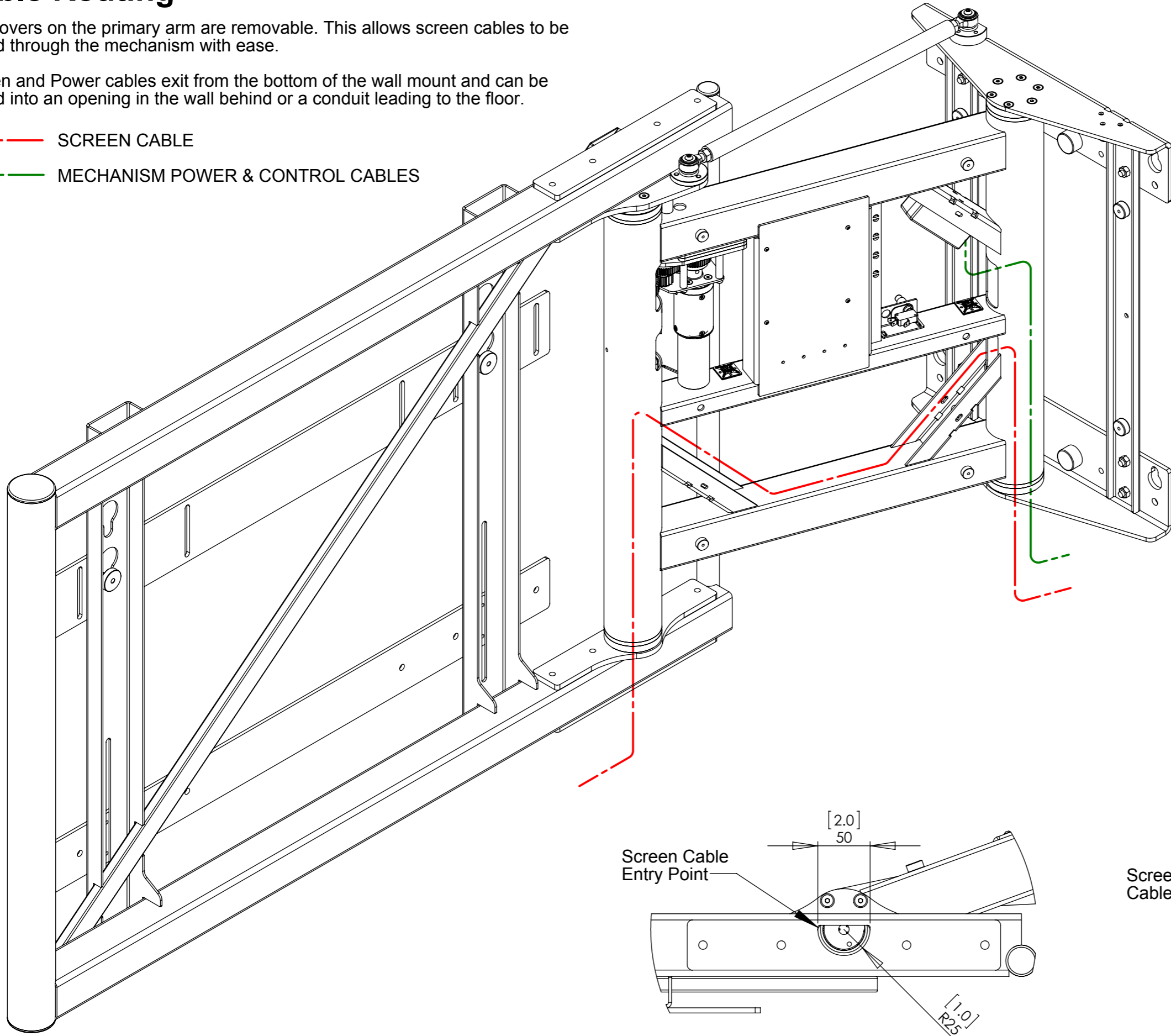

Screen and Mechanism cables must enter an opening in the wall within the dimensions specified above.

Cables that hang lower than 81mm [3.2] beneath the Wall Plate are at risk of damage as the mechanism closes.

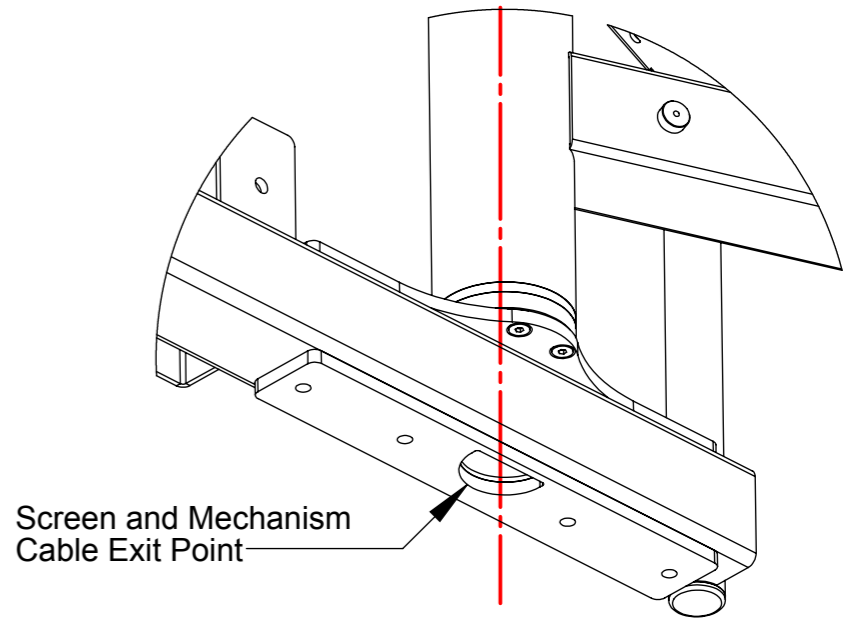
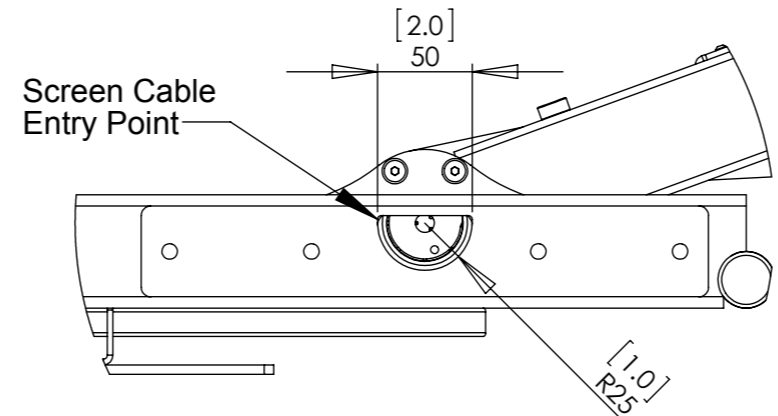

Screen Mounting

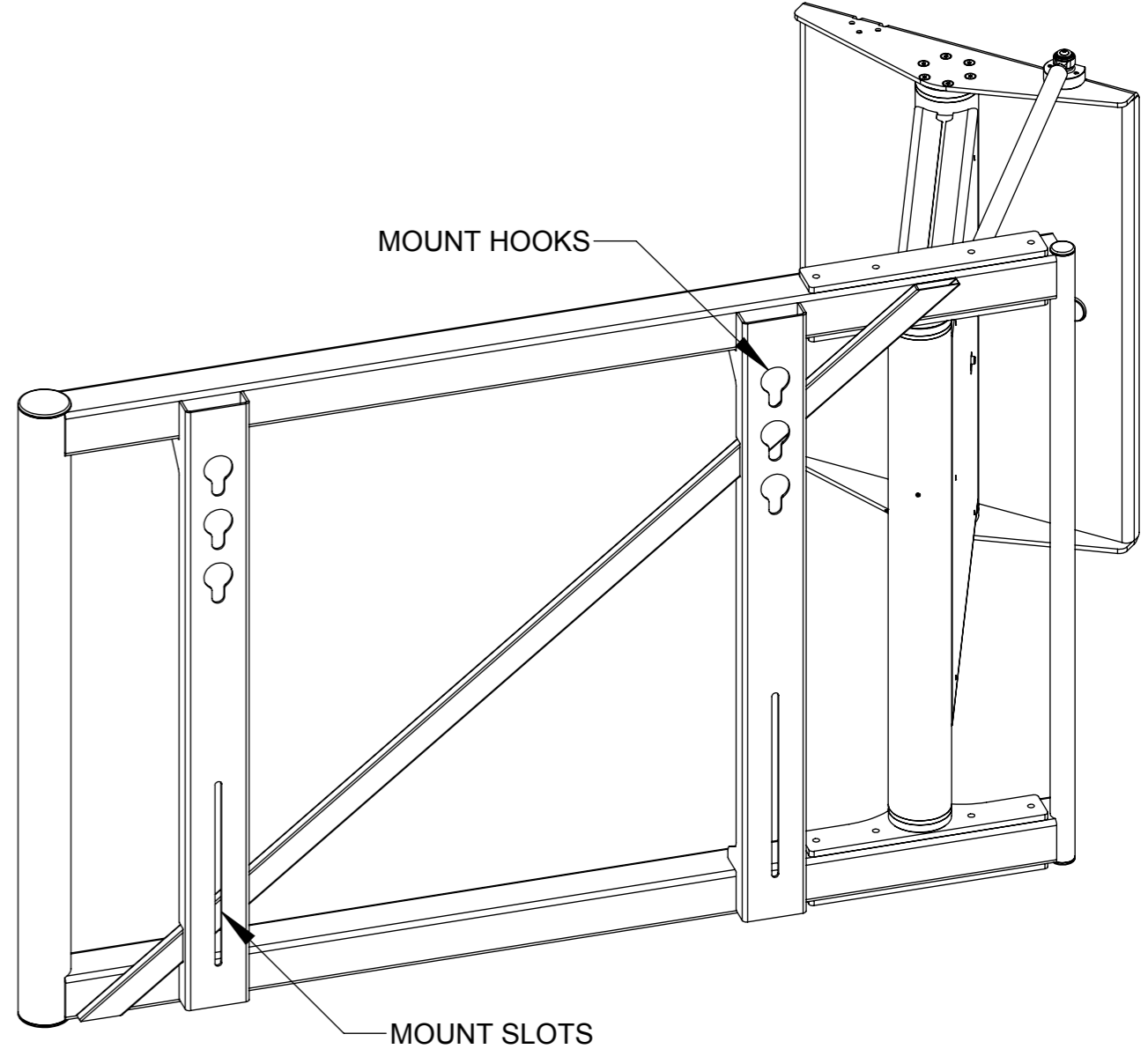
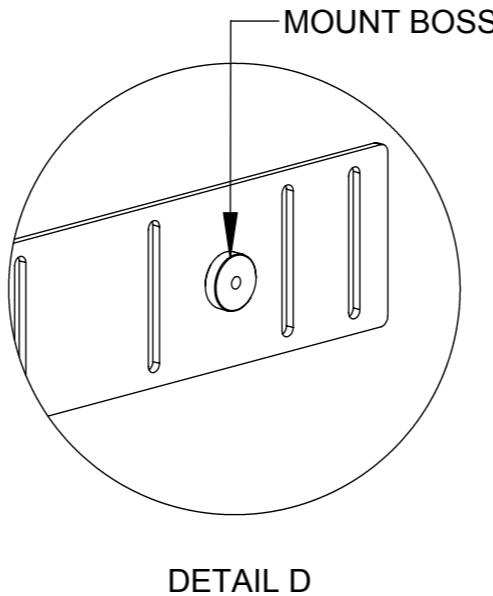
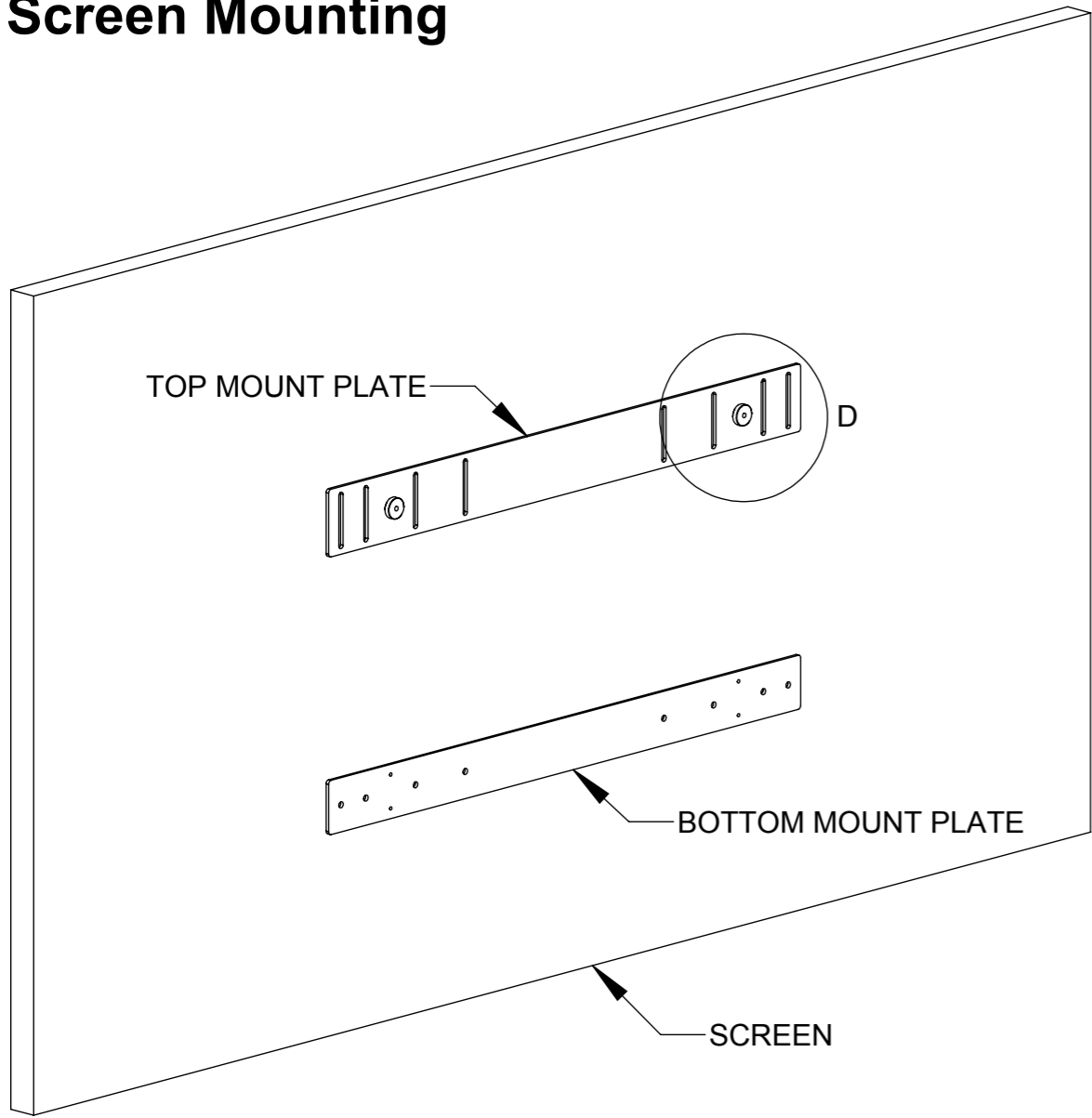

Mounting Method

- 1 - The Top and Bottom Mount Plate are fixed to the back of the screen.
- 2 - The Screen is lifted into position, engaging the two Mount Bosses into the desired Mount Hooks.
- 3 - If the screen position needs adjusting, it can be removed from the mechanism and the Top Mount Plate can be re-positioned to suit. The screen can then be lifted back onto the mechanism.
- 4 - The Bottom Mount Plate is secured through the Mount Slots.

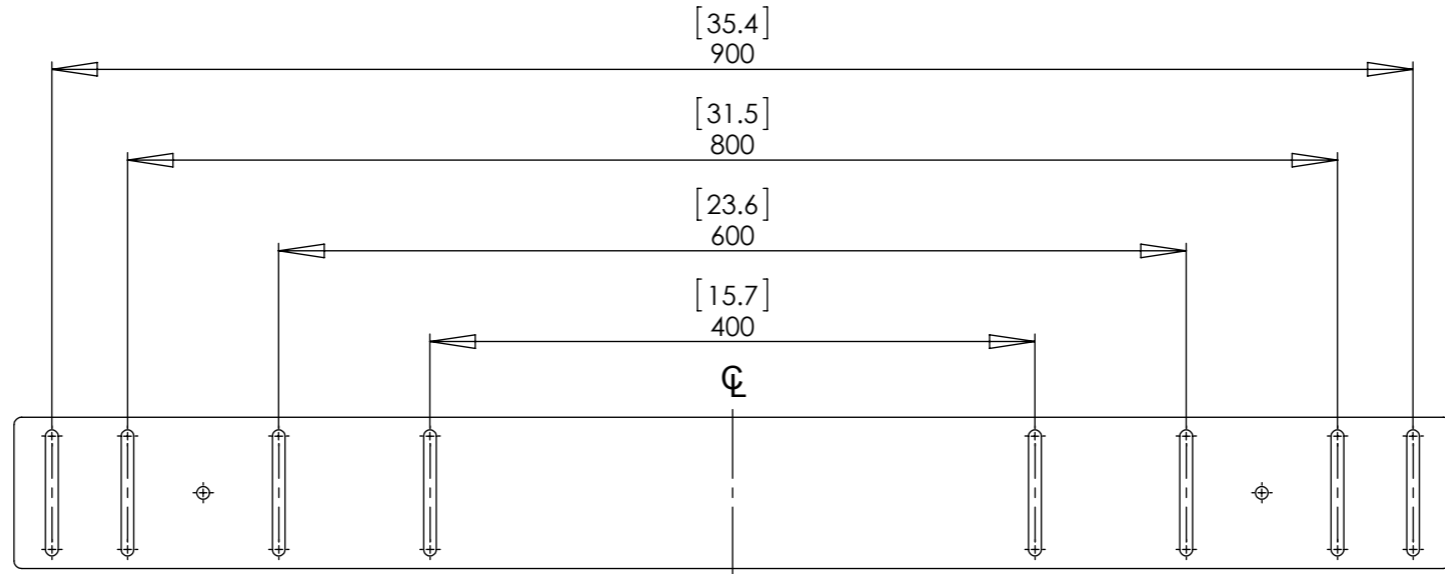

The mechanism is suitable for the following screen mount patterns:

- 900x600
- 800x400
- 600x400
- 400x400

Custom solutions for alternative mount patterns can be provided.



Recess Mounting

Screen dimensions must be carefully considered when mounting the mechanism in a recess.

Deeper screens will require a deeper recess which may obstruct part of the screen at the full 90° extension.

If the full 90° extension is not required, this may not be an issue.

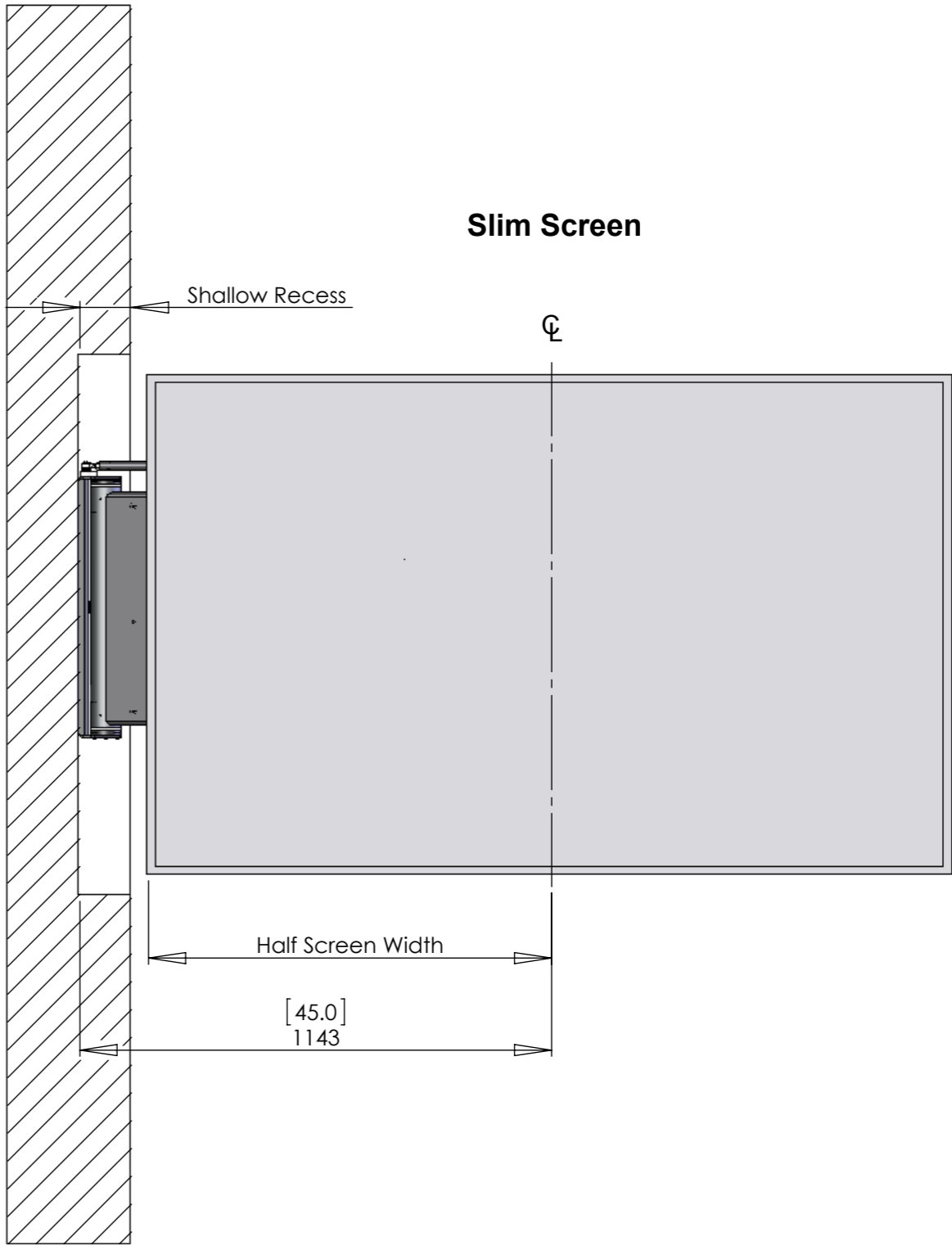
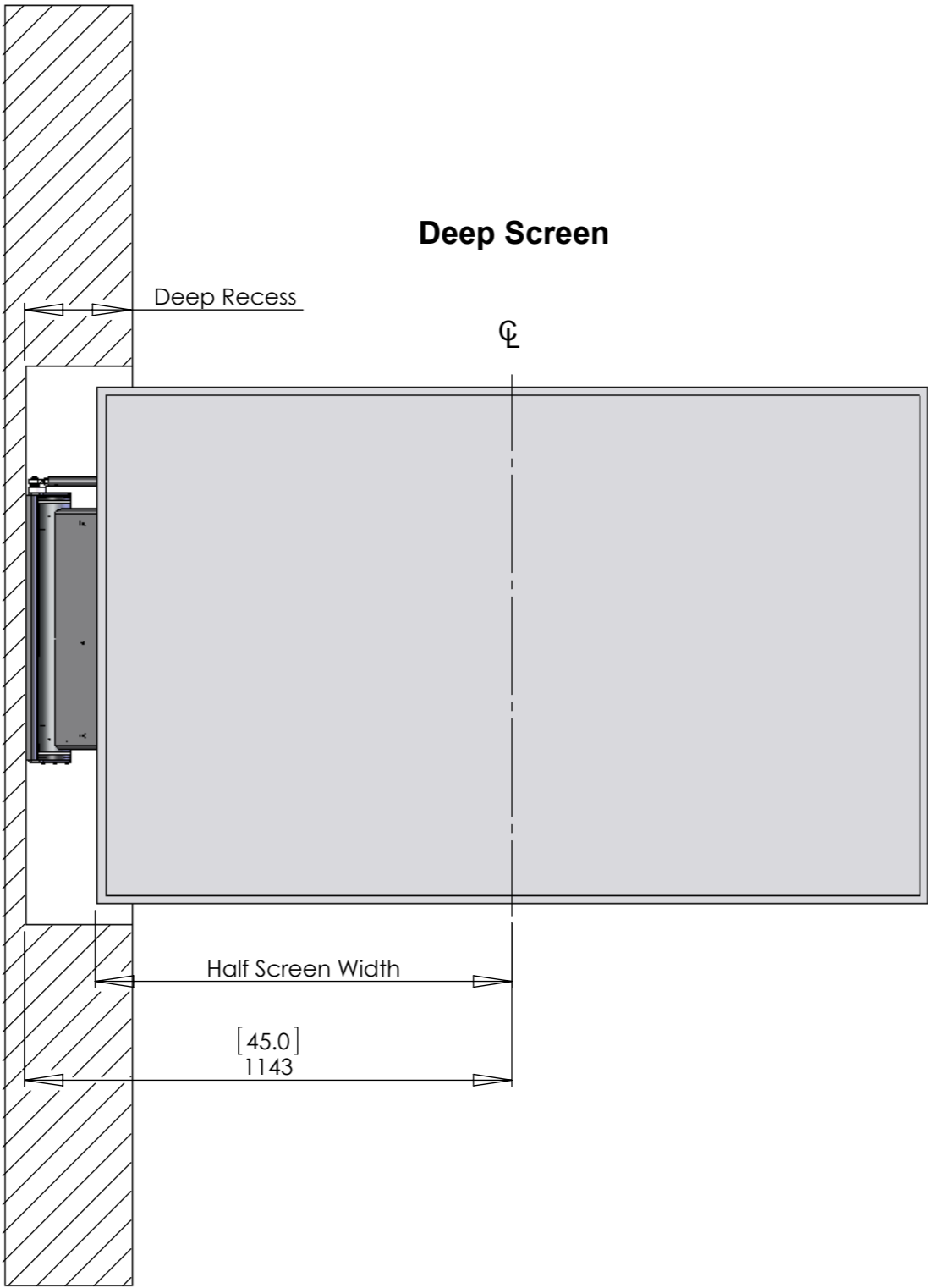

General Dimensions - IN Position

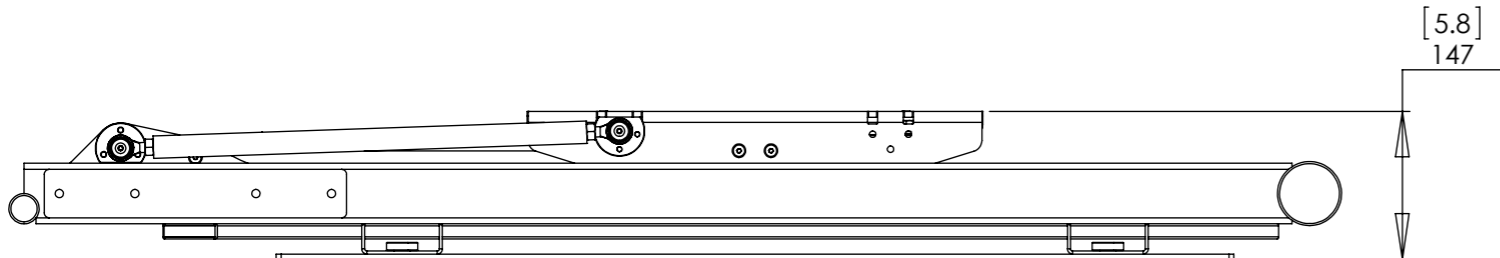
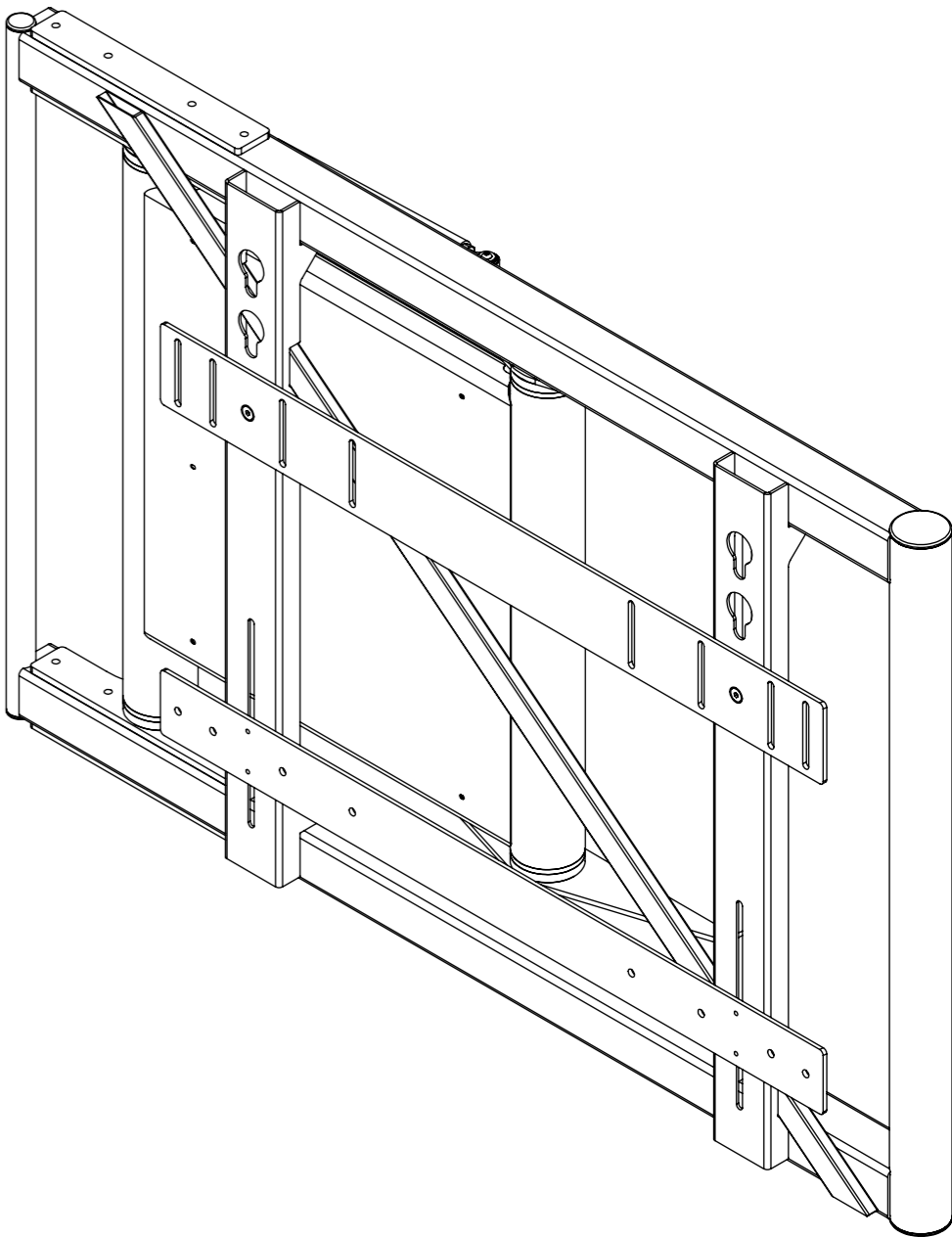
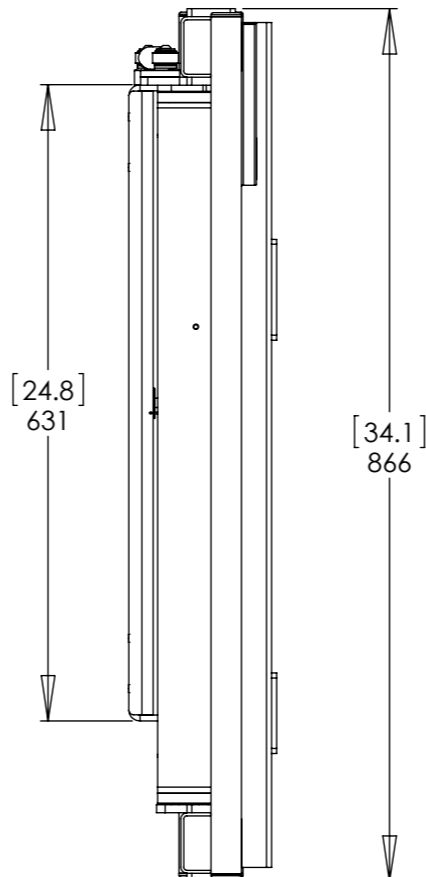
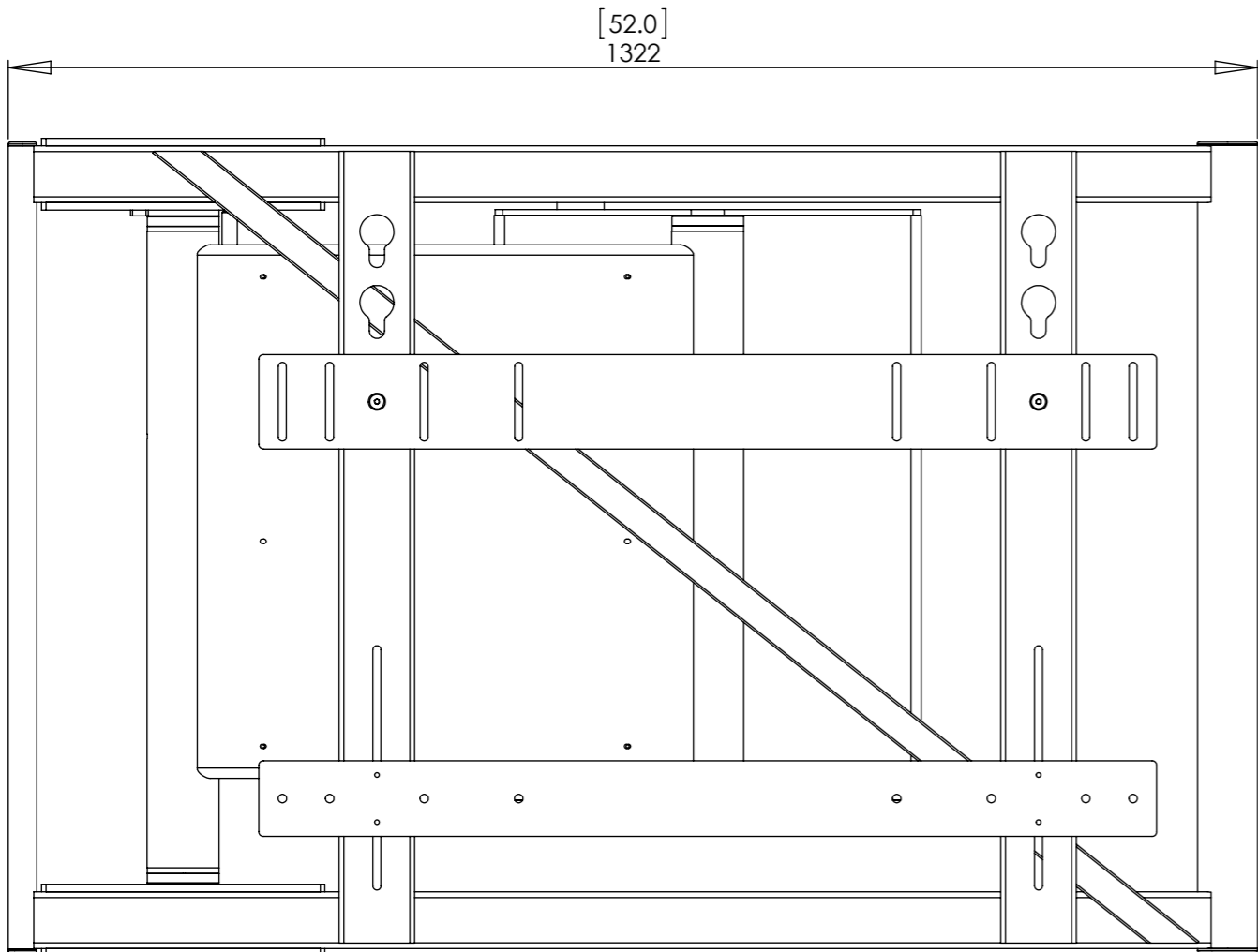
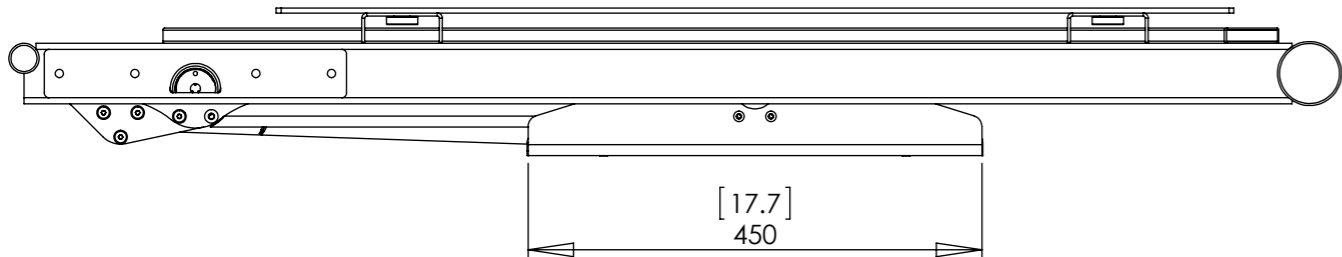

General Dimensions - 90° OUT Position

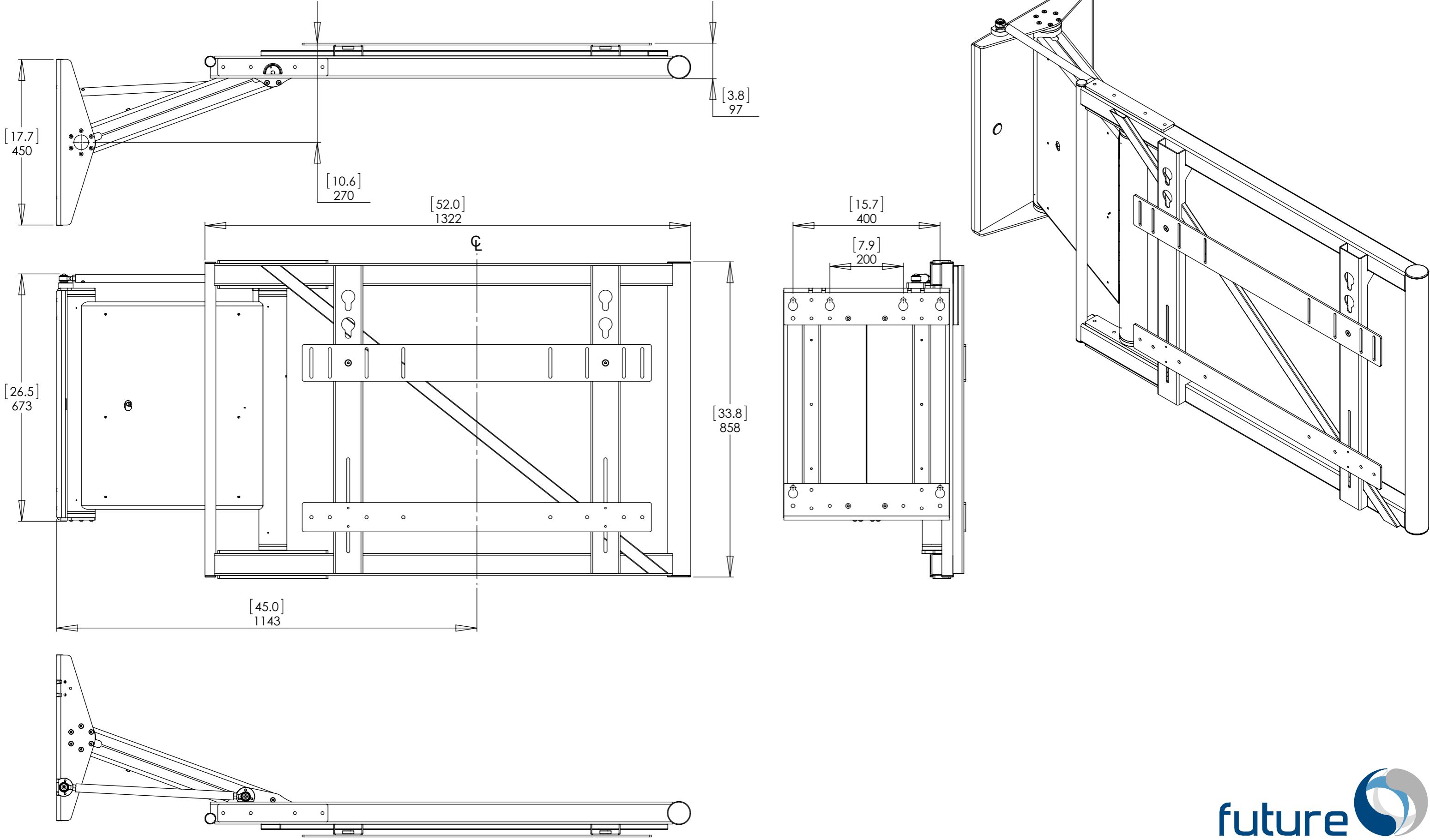

Wall Mount Dimensions

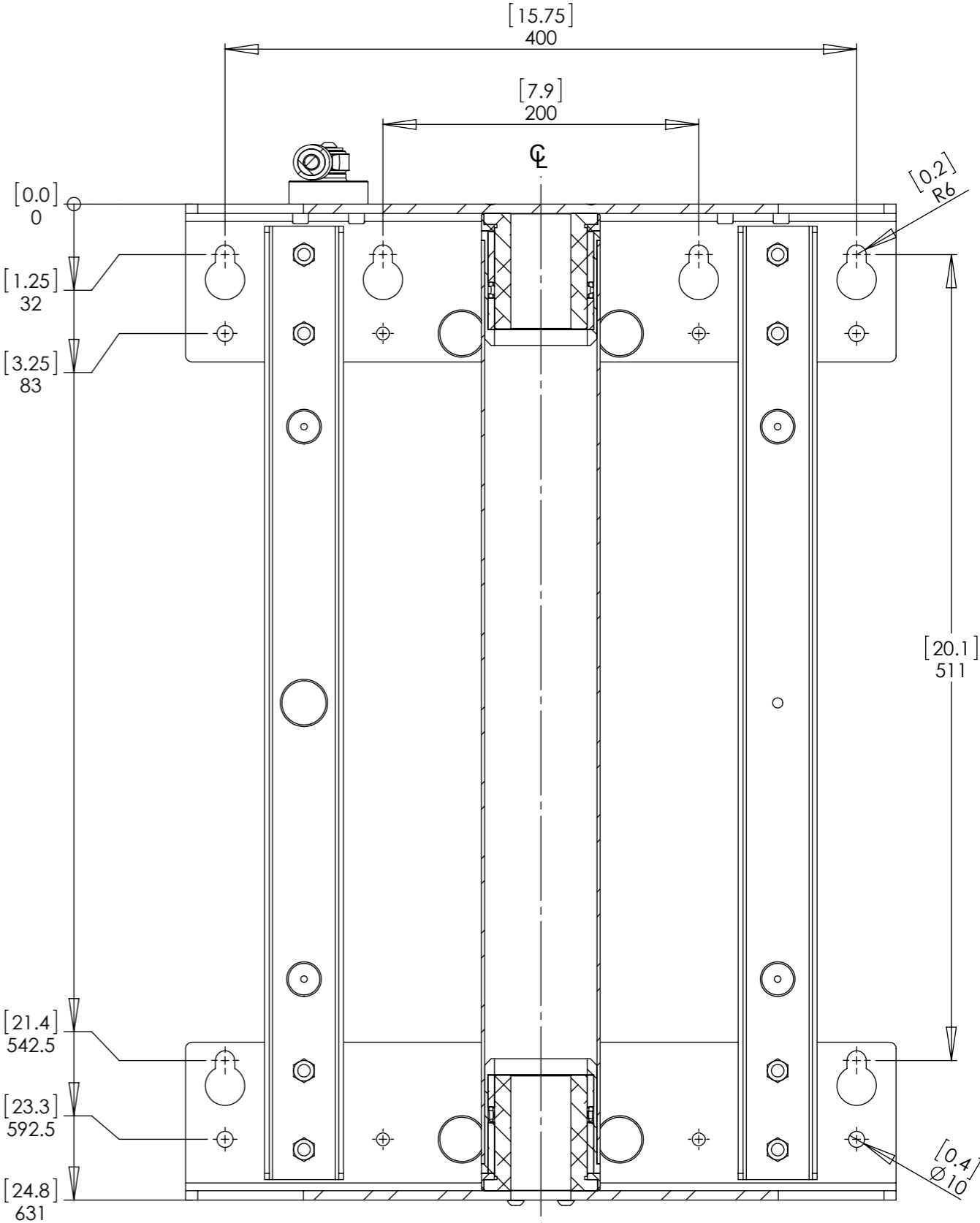
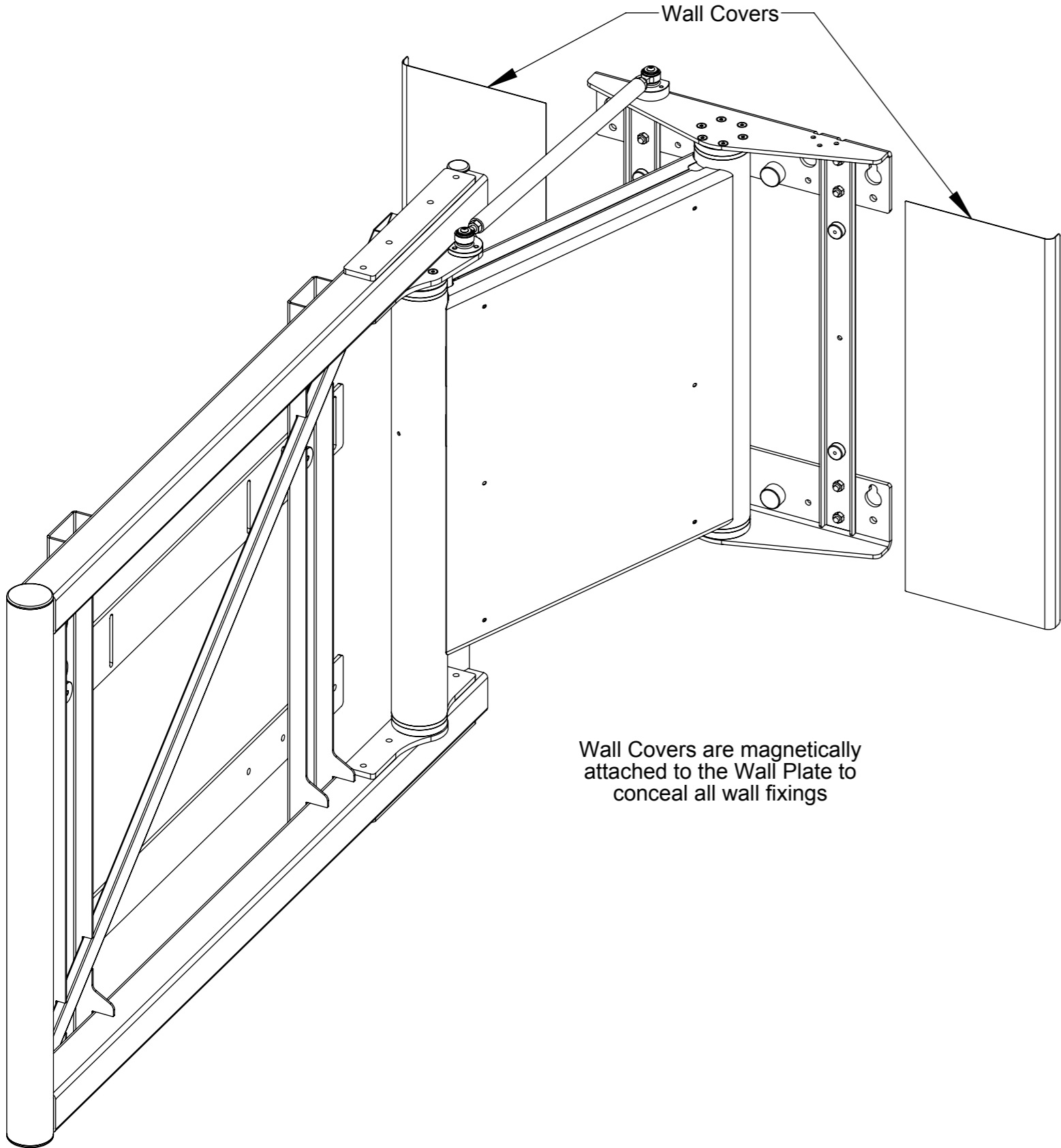

SECTION B-B

Preset Positions

A number of positions are preset in the mechanism.

Each of the positions shown below can be achieved by pressing the corresponding button on the remote control.

All of the positions can be changed, apart from the IN and OUT positions.

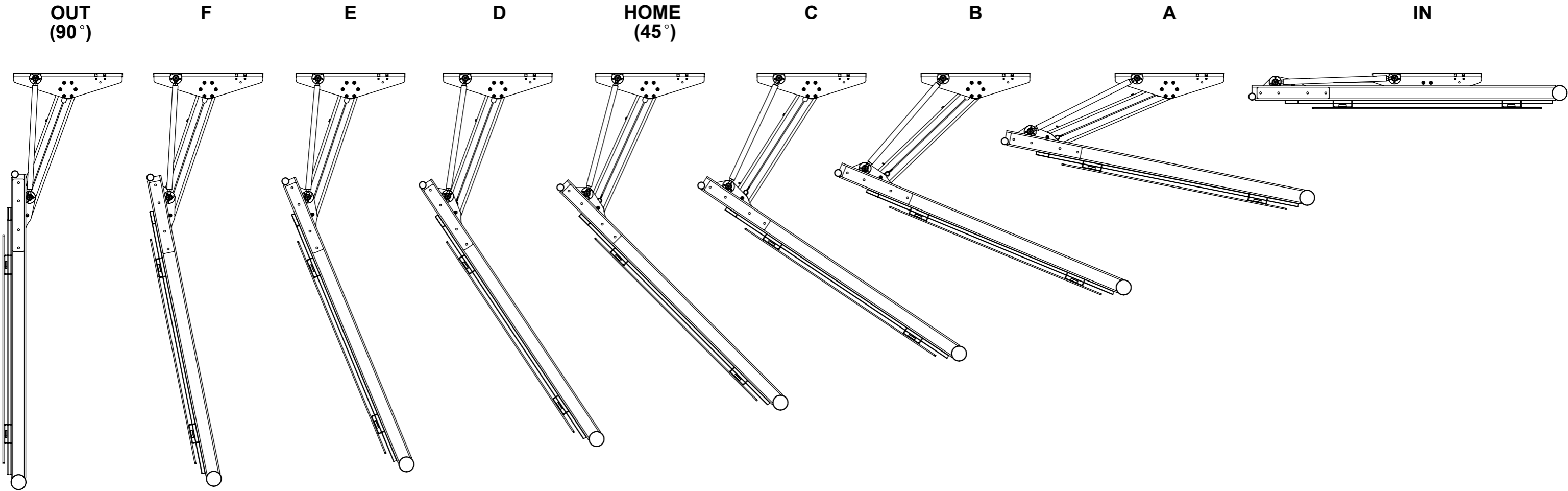

Maximum Viewing Angles

Screens with a width of more than 2220 [87.4] will not be able to achieve the full 90° of rotation.

The maximum viewing angle of a 2600 [102.4] wide screen is 55°.

