

Installation Instructions

AL675 - UDC1 Actuator Lift

Design Highlights

- Push up lid
- Full cable management
- Compact design for minimum spatial requirements
- Only 20mm of height above television required
- Near silent motor system



Thank you for choosing
futureautomation

AL675 UDC1 Actuator Lift



Caution
Warning



Beware of
Moving Parts



Danger
Electricity



Keep Hands
Clear

Safety Disclaimer

Important Safety Instructions

Explanation of graphical symbols

-(Electric Shock Symbol) = The lightning flash within an equilateral triangle is intended to alert you to the presence of un-insulated "dangerous voltage" within the products enclosure that may be of sufficient magnitude to constitute an electric shock to persons

-(Caution Symbol) = The exclamation point within an equilateral triangle is intended to alert you to the presence of important operating and maintenance (servicing) instructions in the literature accompanying the product

-(Tools Symbols) = The tools symbol within a coloured square are intended to highlight the required tools necessary for correct and safe installation of the product. These are intended as a guide only, and it is at the installer's discretion as to which tools are used.

WARNING: RISK OF ELECTRIC SHOCK, ONLY AUTHORIZED INSTALLERS TO OPEN THE POWER CONTROL BOX.

WARNING: To reduce the risk of fire or electric shock, do not expose electrical parts to rain or moisture, unless the product has been specifically designed to do so.

WARNING: Failure to provide adequate structural strengthening, prior to installation can result in serious personal injury or damage to the equipment. It is the installer's responsibility to ensure the structure to which the component is affixed can support the four times the weight of the component.

WARNING: Do not exceed the weight capacity. This can result in serious personal injury or damage to the equipment. It is the installer's responsibility to ensure that the total combined weight of all attached components does not exceed that of the maximum figure stated.

WARNING: Failure to provide adequate structural strength for this component can result in serious personal injury or damage to equipment! It is the installer's responsibility to make sure the structure to which this component is attached can support five times the combined weight of all equipment. Reinforce the structure as required before installing the component.

Warnings:

1. Read all technical instructions fully before installation and use. It is the installer's responsibility to ensure that all documentation is passed on to the end user and read fully before operation.
2. Keep all documentation.
3. Heed all warnings.
4. Follow all technical specifications and instructions during installation.
5. Do not use near water unless the product has been specifically designed to do so.
6. Clean only with a dry cloth.
7. Do not defeat the purpose of the polarized or grounding type plug. A polarized plug has two blades, one wider than the other. A grounding type plug has two blades and a grounding prong. The wide blade or third prong are provided for your safety. If the provided plug does not fit your outlet, consult an electrician or contact the manufacturer.
8. Protect the power cord from being walked on or pinched, particularly at plugs, convenience receptacles, and the point where the exit from the apparatus.
9. Unplug the apparatus during lightning storms or when unused for long periods of time.
10. Only use attachments/accessories specified by the manufacturer.
11. Refer all servicing to qualified personnel. Servicing is required regularly on an annual basis, when the apparatus is damaged in any way, liquid has been spilled or objects have fallen into the apparatus, the apparatus has been exposed to rain or moisture, does not operate normally, or has been dropped.
12. To completely disconnect the apparatus from the AC mains, disconnect the power cord plug from the AC receptacle on the power control box.
13. To prevent overheating, do not cover the apparatus. Install in accordance with the instructions.
14. UK, Ireland and Hong Kong only – The power cord is supplied with a 13A plug having an earthing pin. The apparatus is earthed and this pin is not required for safety, merely to operate the safety shutter of mains outlet.
15. No naked flames such as lit candles should be placed on the unit.
16. Observe and follow the local regulations when disposing of batteries.
17. Do not expose the unit to dripping or splashing fluids.
18. Do not place objects filled with liquid, such as vases, on the unit.
19. Do not expose the batteries to excessive heat such as sunshine, fire or the like.
20. For all mounted apparatus, the apparatus should be installed on solid wood, bricks, concrete or solid wood columns and battens.
21. Always turn off power at source before putting on or taking off parts and cleaning.
22. Do not use outdoors unless marked for outdoor use.
23. Exceeding the weight capacity can result in serious personal injury or damage to equipment.

Future Sound & Vision trading as Future Automation intend to make this and all documentation as accurate as possible. However, Future Automation makes no claim that the information contained herein covers all details, conditions or variations, nor does it provide for every possible contingency in connection with the installation or use of this product. The information contained in this document is subject to change without prior notice or obligation of any kind. Future Automation makes no representation of warranty, expressed or implied, regarding the information contained herein. Future Automation assumes no responsibility for accuracy, completeness or sufficiency of the information contained in this document.

AL675 UDC1 Actuator Lift

Contents	Page
Introduction	
Safety Information	1
Contents	2
Contents	3
Tool Indicator Icons	3
Installation	
Parts List	
Package Contents	4
Stage 1	
Before You Start	5
Resetting The AL675	5
Stage 2	
Fixings To The Cabinet	6
Stage 3	
Releasing The Screen Uprights	7
Stage 4	
Aligning The Screen	8
Stage 5	
Mounting The Screen	9
Stage 6	
Inserting The Shelf	10
Stage 7	
Connecting The Push Bar	11
Stage 8	
Final Checks	12
Electrical Connections	
Contact Closure	13
IR Controls	14
RF Controls	15
Operations	
IR Control	14
IR Operation	14
Storing Positions	14
Changing Batteries	14
RF Control	15
RF Operation	15
Trouble Shooting	16
Technical Overview	17

AL675 UDC1 Actuator Lift

Tool Indicator Icons

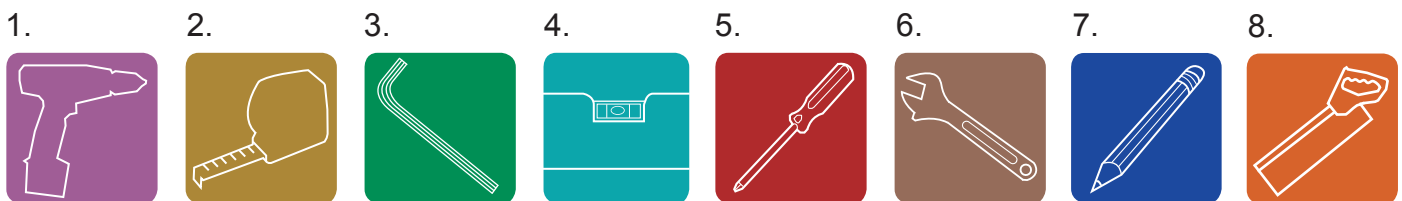

1. - Drill

2. - Tape measure

3. - Allen Keys

4. - Spirit Level

5. - Screwdrivers

6. - Spanners

7. - Pencil

8. - Saw

Product Warranty

This product carries a warranty that covers the cost of labour and spare parts incurred by any defects in materials and workmanship under normal use during a two year period from date of purchase. Support for any problems that are not hardware faults are excluded from the warranty entitlement. This warranty does not affect your statutory consumer rights.

The following is excluded from warranty service:

- Malfunctioning caused by misuse or damage, accidental or otherwise, or service modification by persons not authorised by Future Automation, or the use of any non Future Automation supplied parts;
- Any electrical, or other environmental work external to your Future Automation mechanism including power cuts, surges or lightning strikes;
- Additional items not supplied by Future Automation although they may have been supplied together by the retailer;
- Any 3rd party software products controlling your mechanism;
- Any transfer of ownership. Warranty is provided only to the initial purchaser;
- Compensation for loss of use of the product, and consequential loss of any kind;
- Use of the product over the specified weight capacity;
- Any damage to products during transit that is not checked and notified as "unchecked" or "damaged" upon receipt of delivery.

Any part of your system that needs to be replaced during a warranty repair becomes the property of Future Automation.

AL675 UDC1 Actuator Lift

Package Contents

- 1 - Mechanism
- 1.1 - Base Plate
- 1.2 - Linear Actuator
- 1.3 - Base Shelf
- 1.4 - Shelf Bracket
- 1.5 - Cable Management Bracket
- 1.6 - Top Bracket
- 1.7 - Screen Plate
- 1.8 - Screen Uprights
- 1.9 - Push Bar
- 1.10 - Cable Management
- 2 - Remote Control
- 3 - Control Box

Not Shown On Page

- 5 - x2 AAA Batteries
- 6 - Multi Pack Of Nuts, Bolts & Washers
- 7 - Mains Power & Other Leads
- 8 - Felt Pad

Nuts & Bolts Multipack:

A range of nuts, bolts, washers and spacers to help add in the mounting for your screen

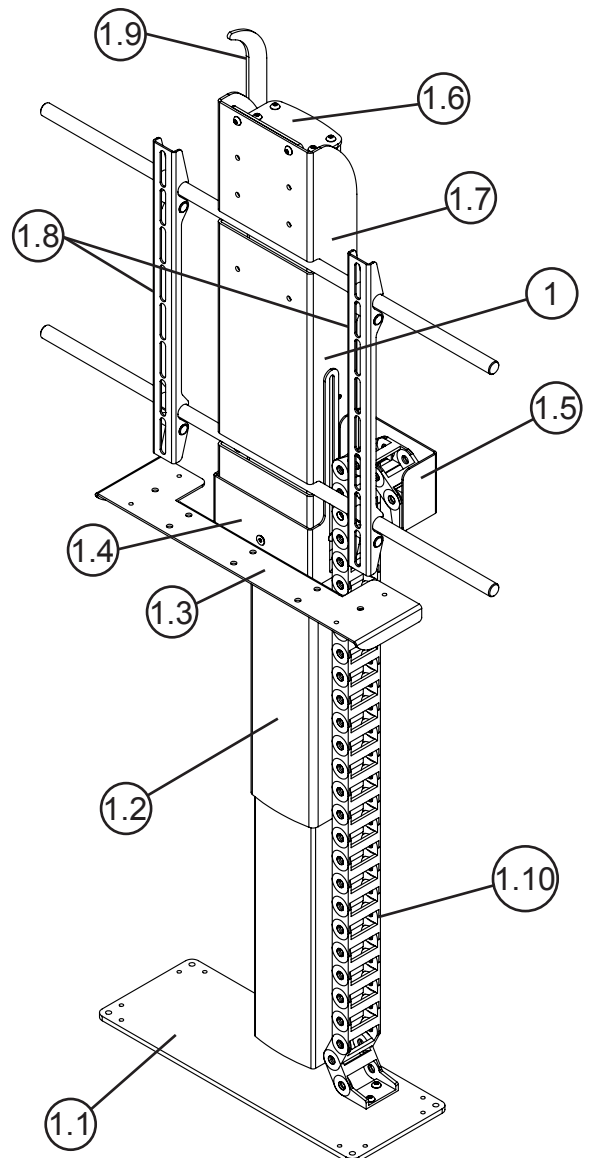
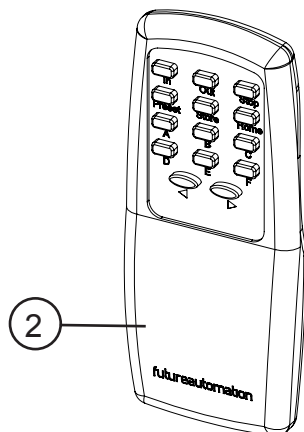
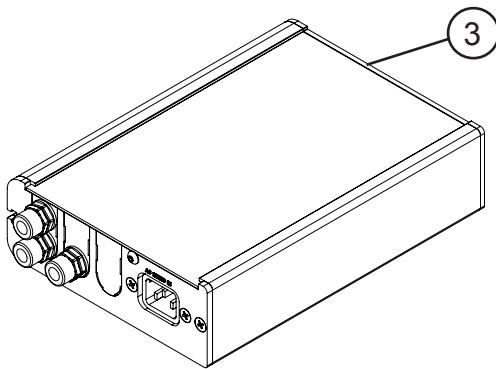

AL675 UDC1 Actuator Lift

Before you start

Prior to installation check the following:

- The product is in good condition
- No damage to any parts
- Wiring is all secure
- The unit is in the closed position
- Test the mechanism by running it up and down

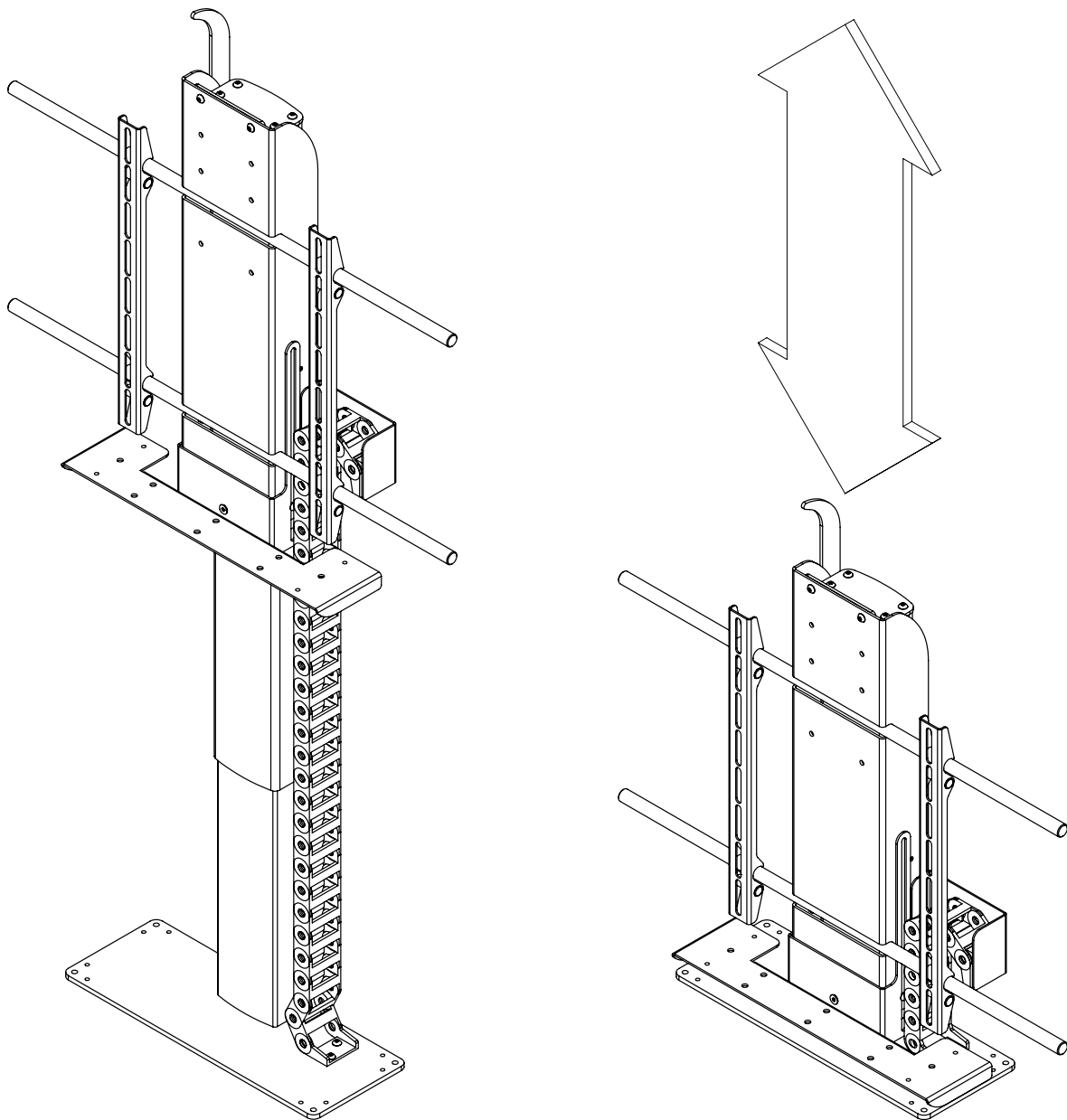

AL675 UDC1 Actuator Lift



Fixing to the cabinet

-Place the mechanism into the cabinet and fix into place (fixings not supplied.)

- Check the measurements of the cabinet to the technical sheet

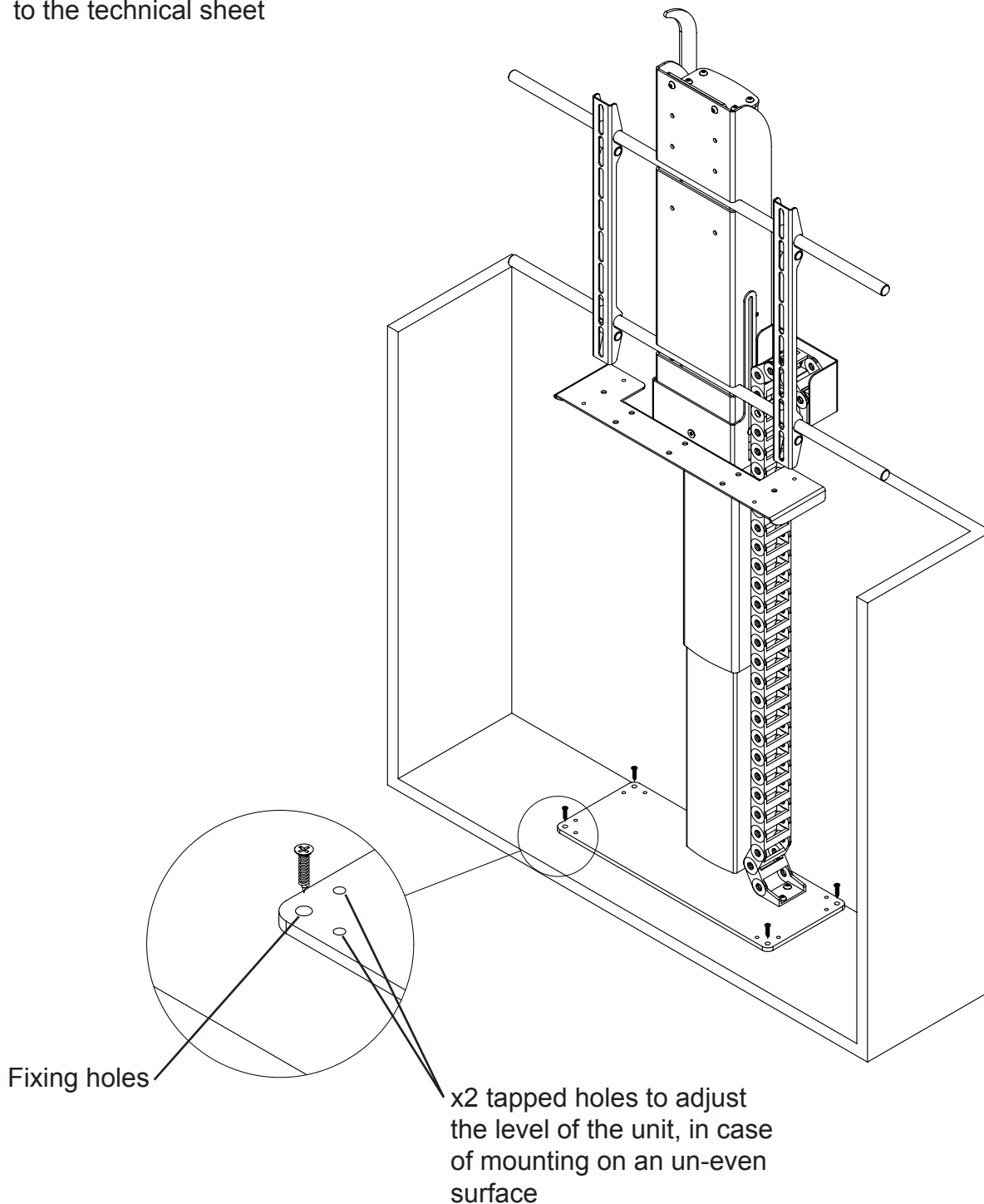

AL675 UDC1 Actuator Lift



Releasing the screen uprights

Loosen upright bolts as shown to release screen uprights from screen plate

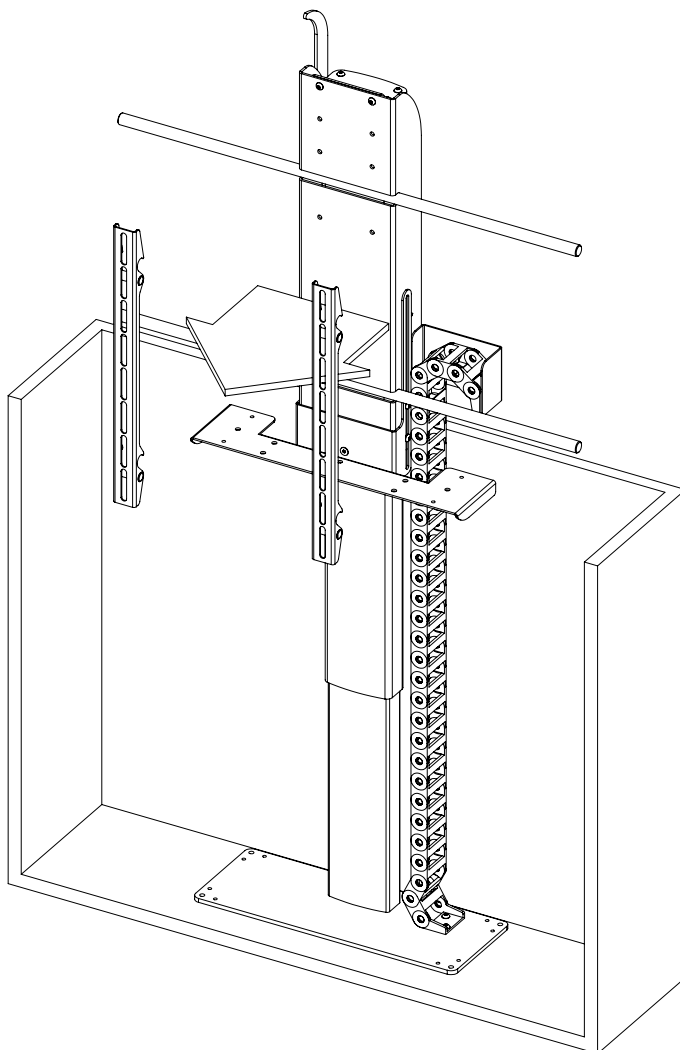
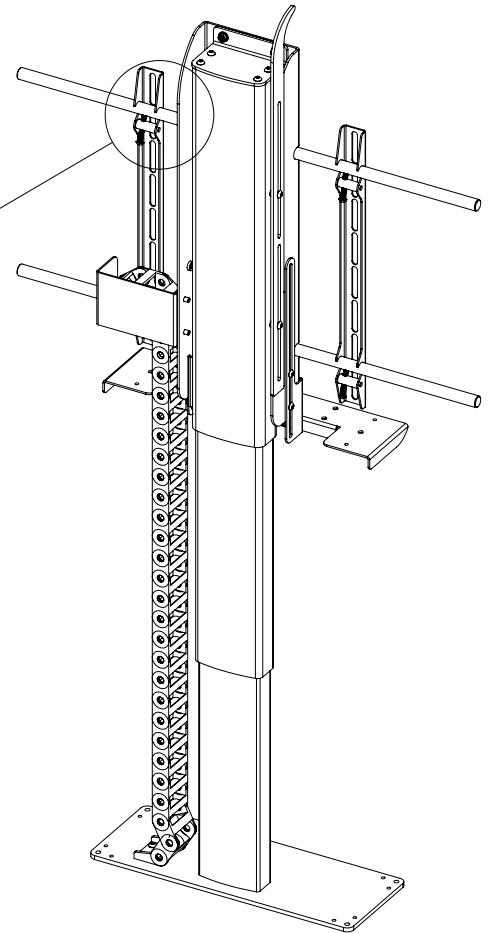
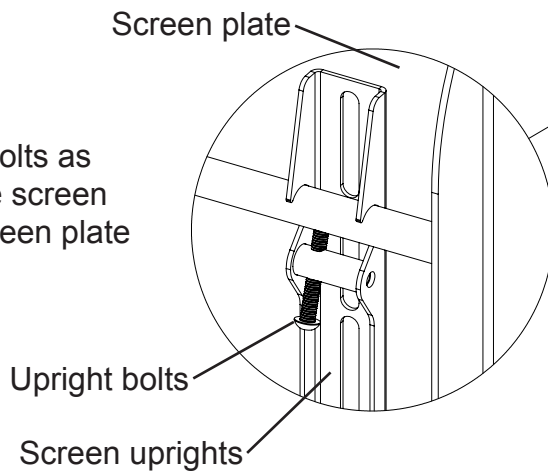

- Remove screen up rights by unhooking over horizontal bars
- Organise cables so they run through the cable management chain and are neatly organised in the bottom of the cabinet

AL675 UDC1 Actuator Lift



Aligning the screen

Align the top of the screen so that it's just below the underside of the lid when the mechanism is in the IN position

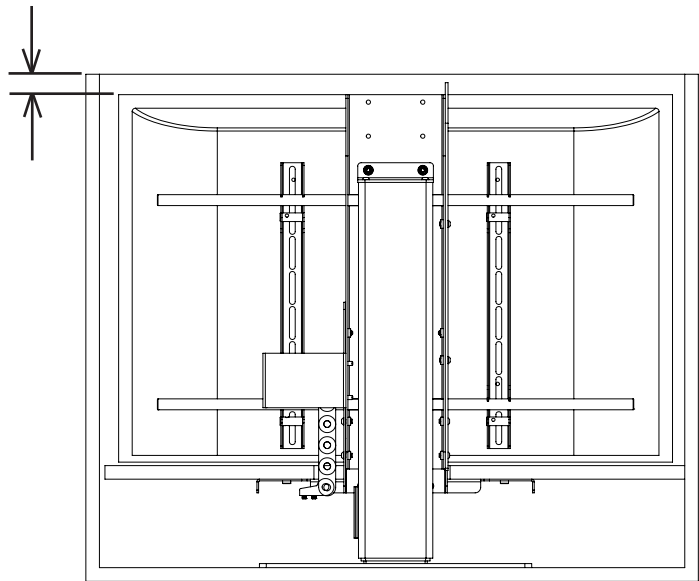

Change the height of the screen by altering the mounting holes in the screen plate

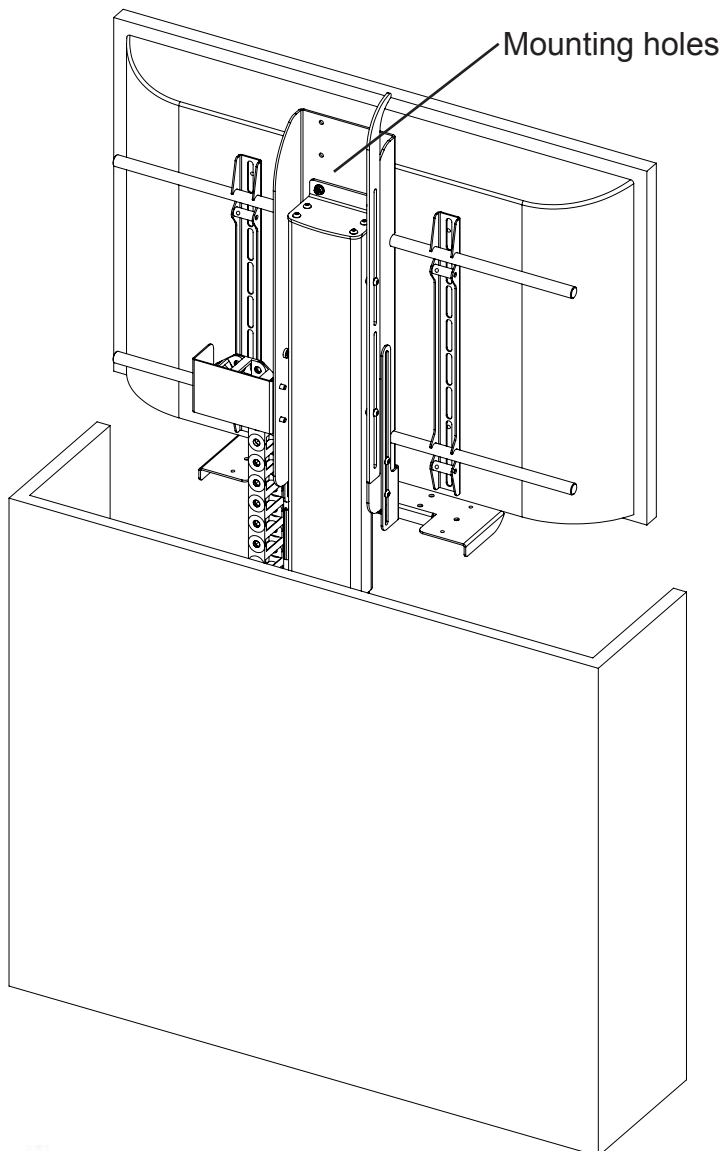

AL675 UDC1 Actuator Lift



Mounting the screen

- Place the screen uprights into position on the back of the screen
- Secure into place using the range of nuts, bolts and washers provided

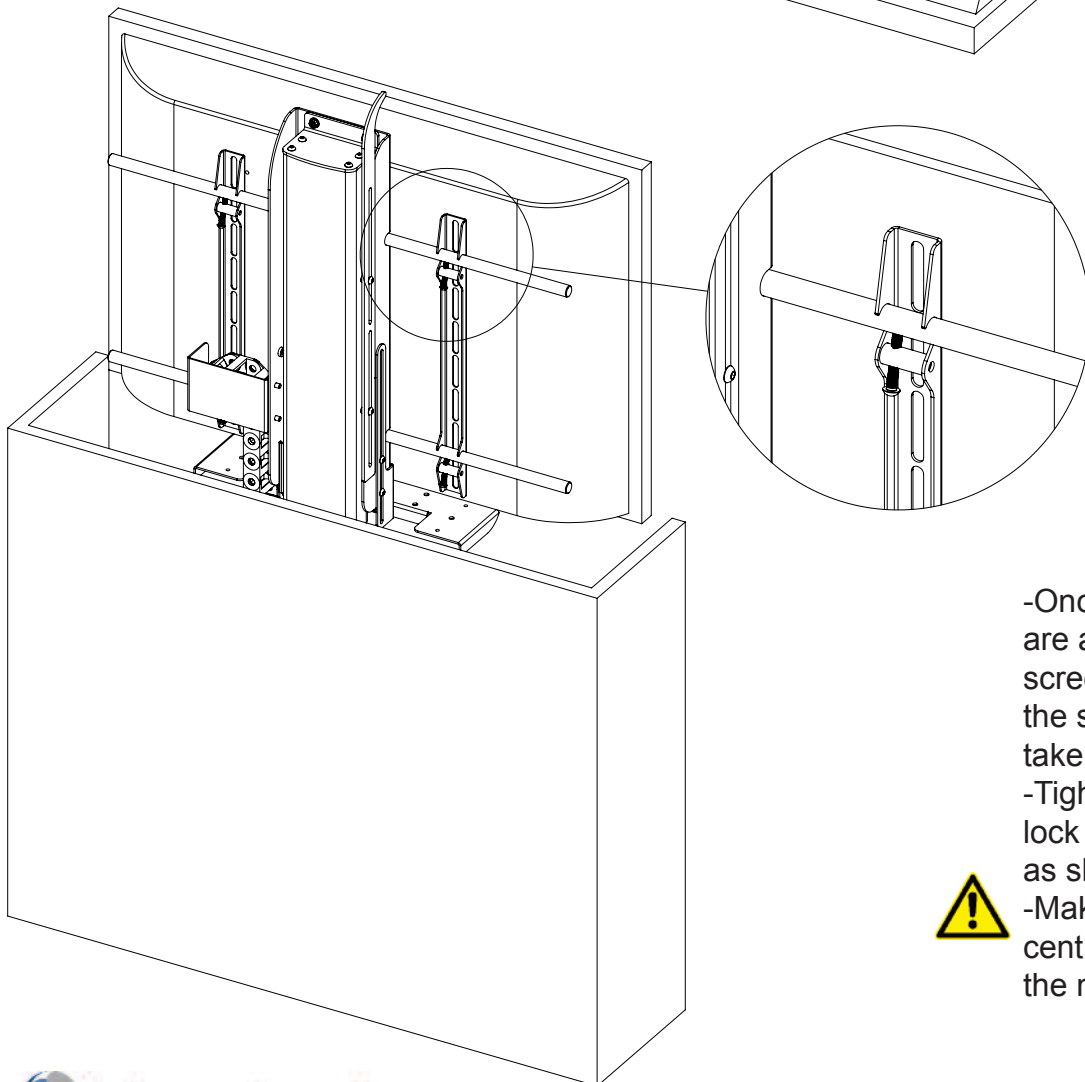
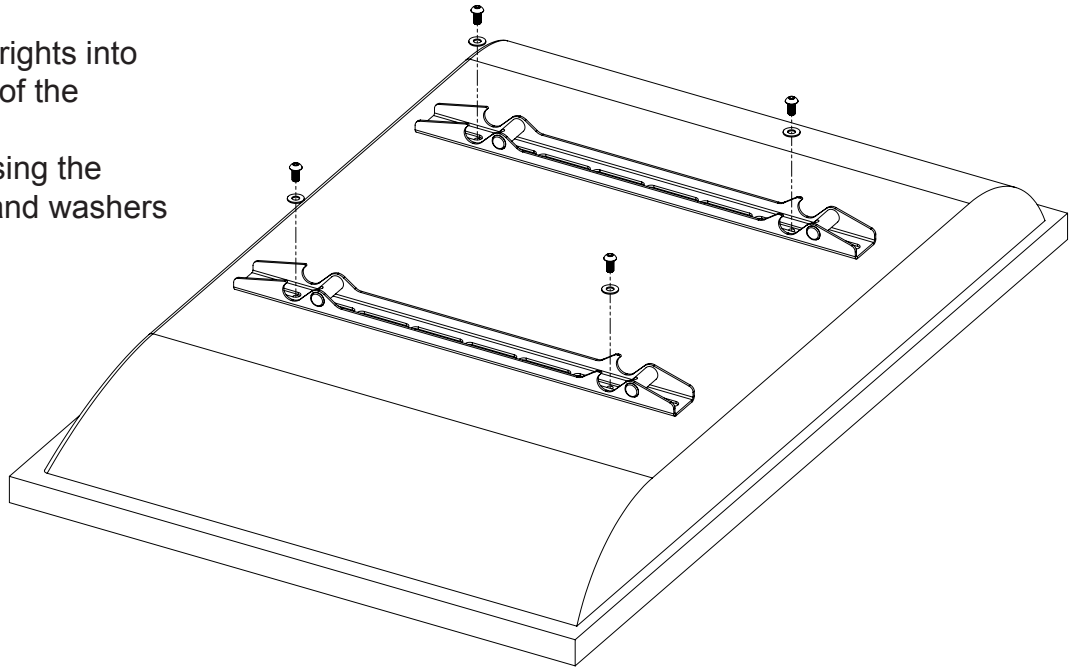

- Once the screen uprights are attached, overlap the screen to the horizontal bars the same way as they were taken off
- Tighten x4 bolts back up to lock the screen into position as shown in the detail view
- Make sure the screen is centralized in the middle of the mechanism



AL675 UDC1 Actuator Lift



Inserting the shelf

Adjust the fixings on the shelf bracket to determine the height of the shelf. Change the height of the shelf so that it fills the void neatly and sits flush to the top surface

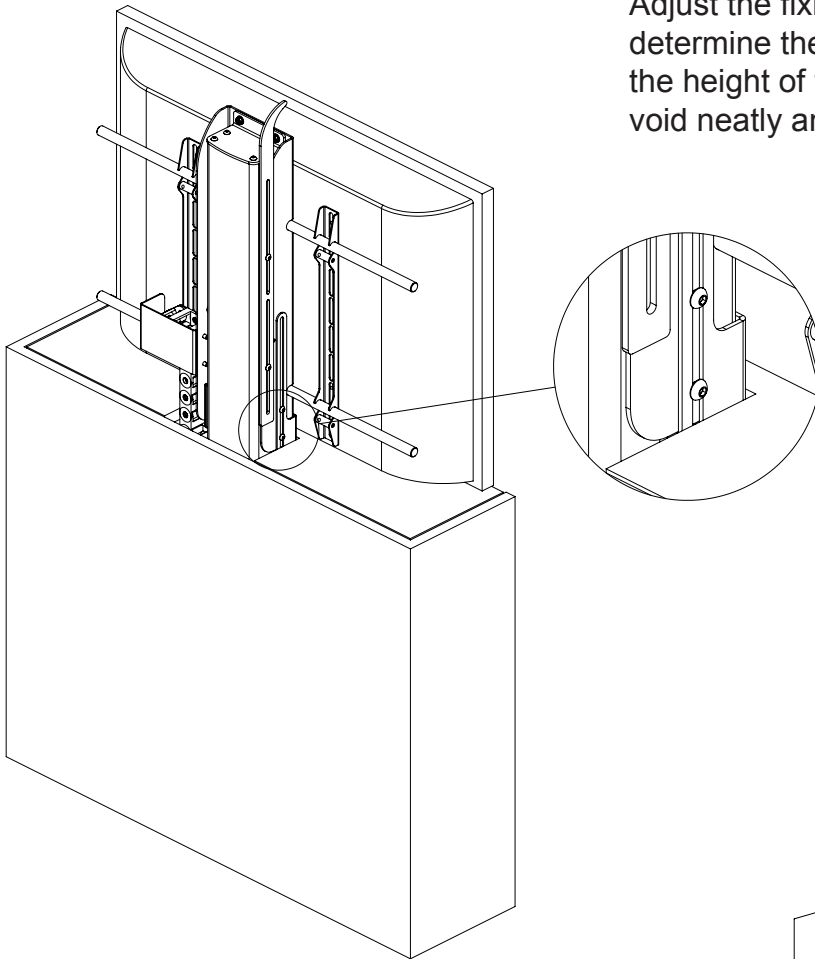

- Slide the shelf into position under the screen and on top of the base shelf
- Secure into place through the middle holes on both sides
- Optional* - Use bolts in the corners to push up and level the shelf.

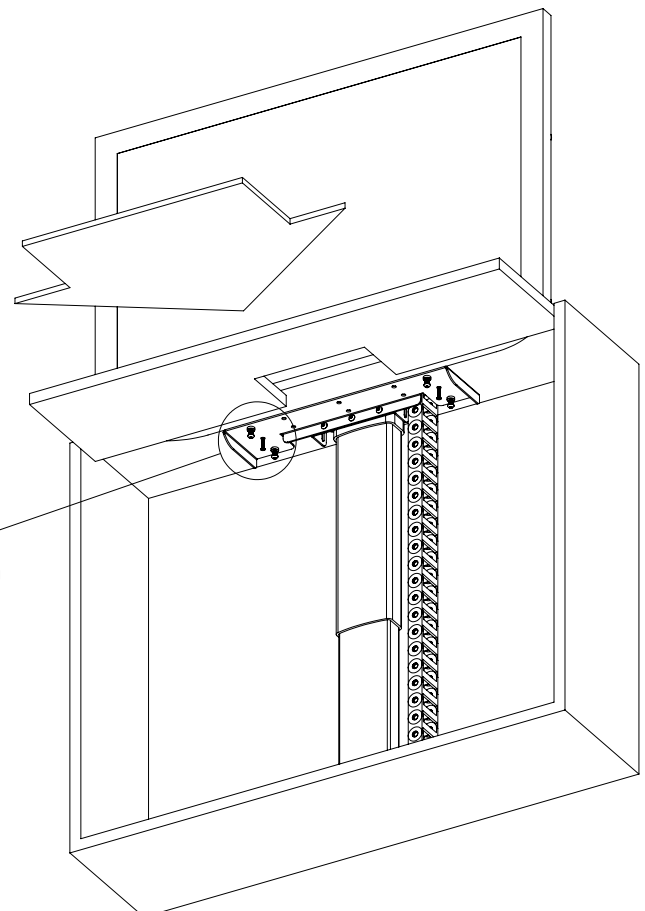
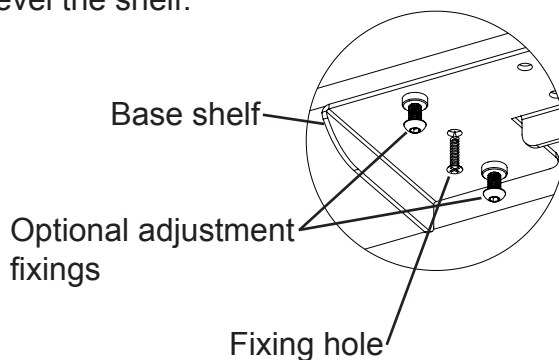

AL675 UDC1 Actuator Lift



Connecting the push bar

-Stick the felt pad onto the underside of the lid so it's in-line with the push bar.



-Make sure that when the mechanism opens the push bar is in contact with the felt pad

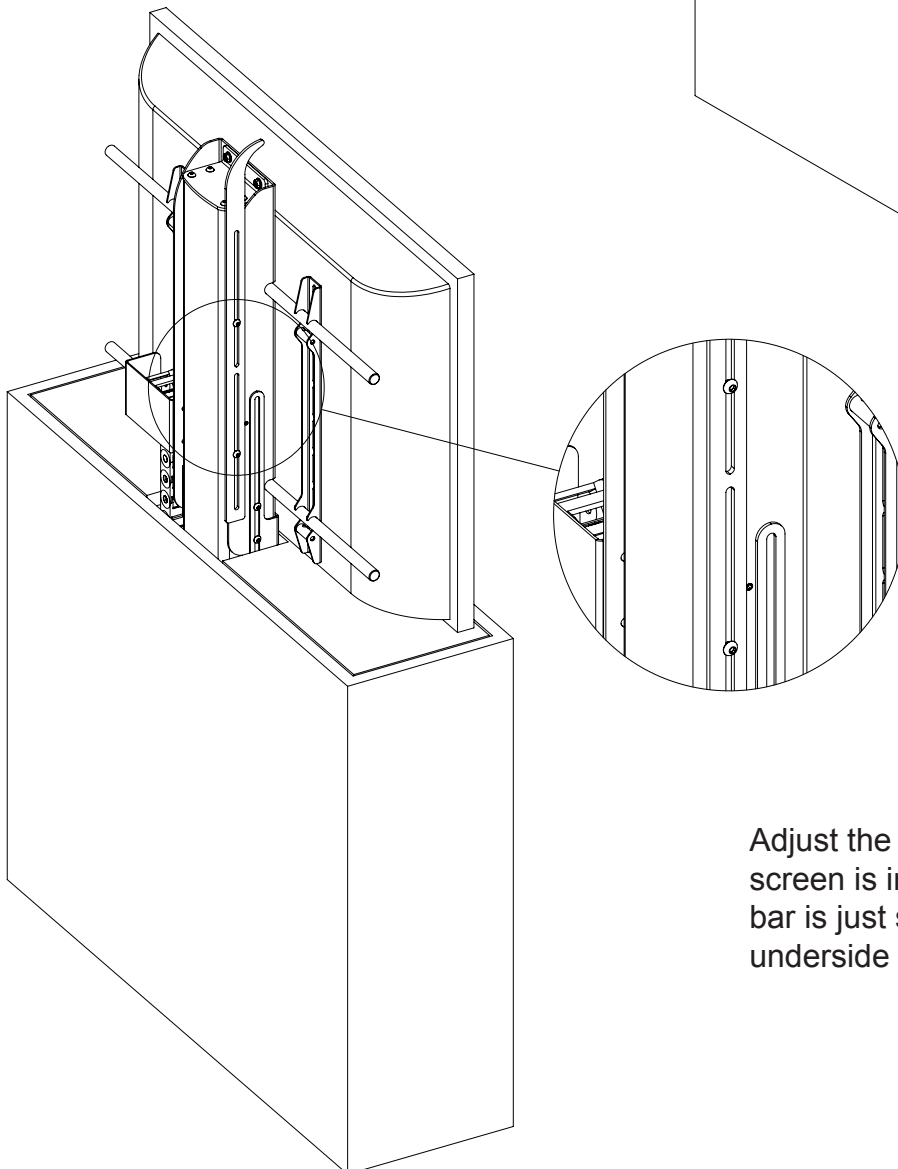
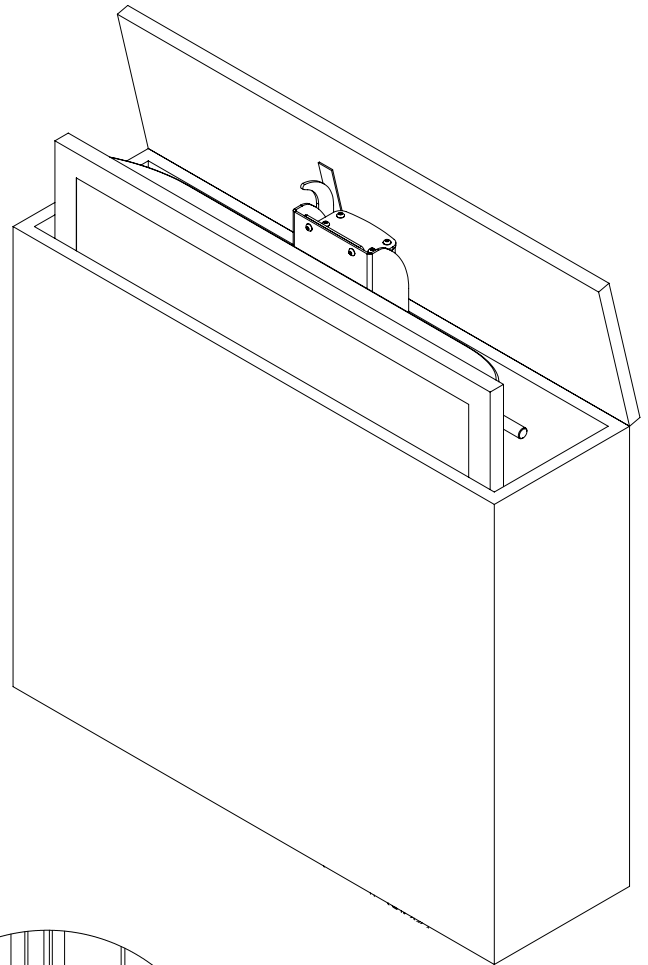

Adjust the push bar so when the screen is in the IN position the push bar is just short from touching the underside of the lid

AL675 UDC1 Actuator Lift



Final checks

Final movement.

Make sure the unit runs smoothly and that the push bar hits and then runs along the felt pad.

- Make sure that the lid doesn't fall back over its self when the unit opens.
- Product is level and square in the cabinet
- The mechanism runs smoothly and to the stored positions

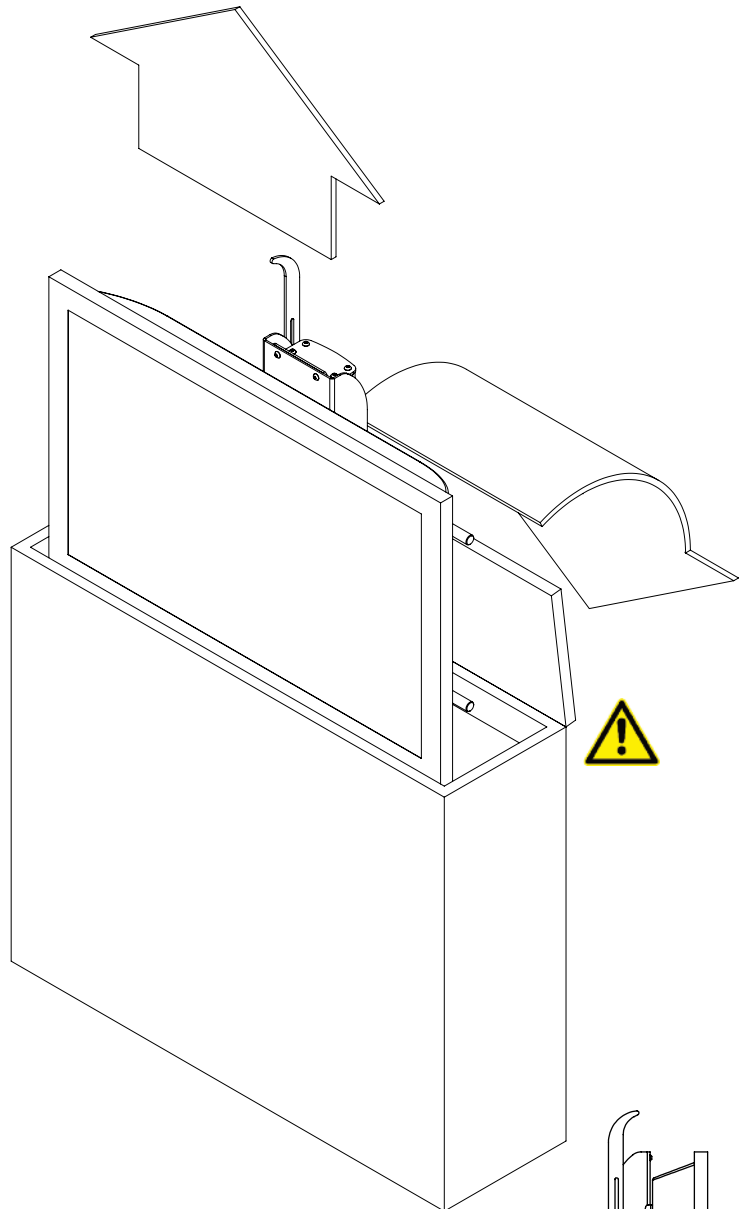

The mechanism movement should look like this:

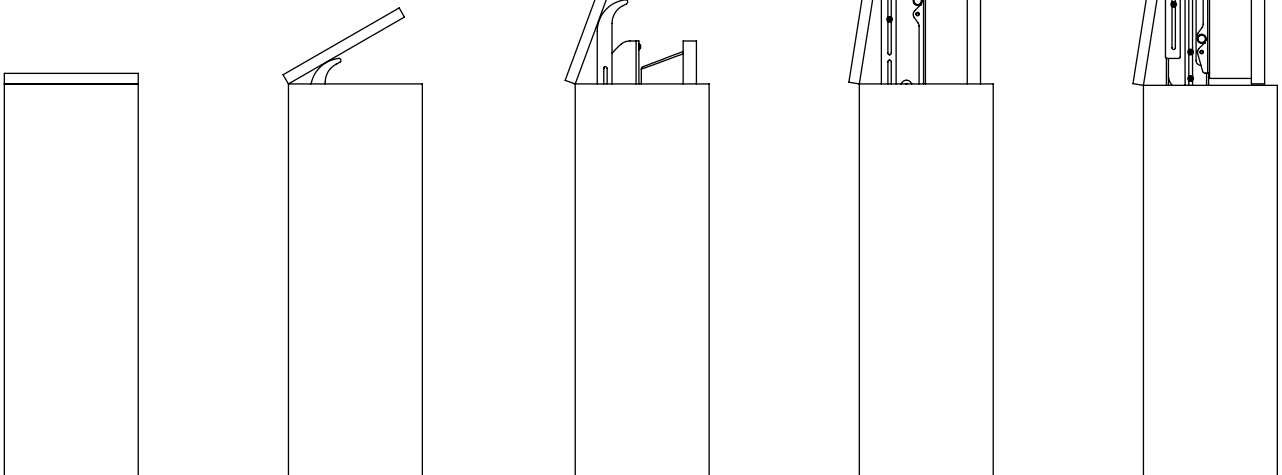

AL675 UDC1 Actuator Lift



Contact Closure

- Use an RJ45 connector in the appropriate socket on the control box to operate via contact closure

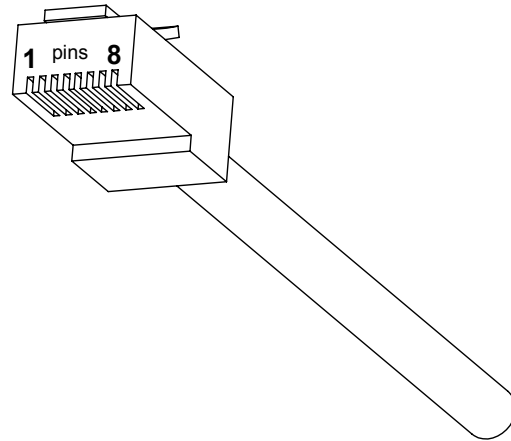

PIN	DESCRIPTION	ACTION	WIRE / CABLE		CONTACT CLOSURE LED INDICATOR
			568A	568B	
1	12V SUPPLY	12V SUPPLY - CURRENT LIMITED	W/G	W/O	
2	12V LATCH	When 12V attached, device will go OUT. When 12V removed device will go IN.	G	O	
3	GROUND	GROUND	W/O	W/G	
4		PIN 4 NOT USED	BL	BL	
5	DEVICE LATCH	Momentary short to GROUND (pin 3), stops device in current position.	W/BL	W/BL	LED 4
6	DEVICE STOP	Momentary short to GROUND (pin 3), stops device in current position.	O	G	LED 3
7	DEVICE OUT	Momentary short to GROUND (pin 3), makes device go OUT.	W/BR	W/BR	LED 2
8	DEVICE IN	Momentary short to GROUND (pin 3), makes device go IN.	BR	BR	LED 1

AL675 UDC1 Actuator Lift



IR Controls General Wiring

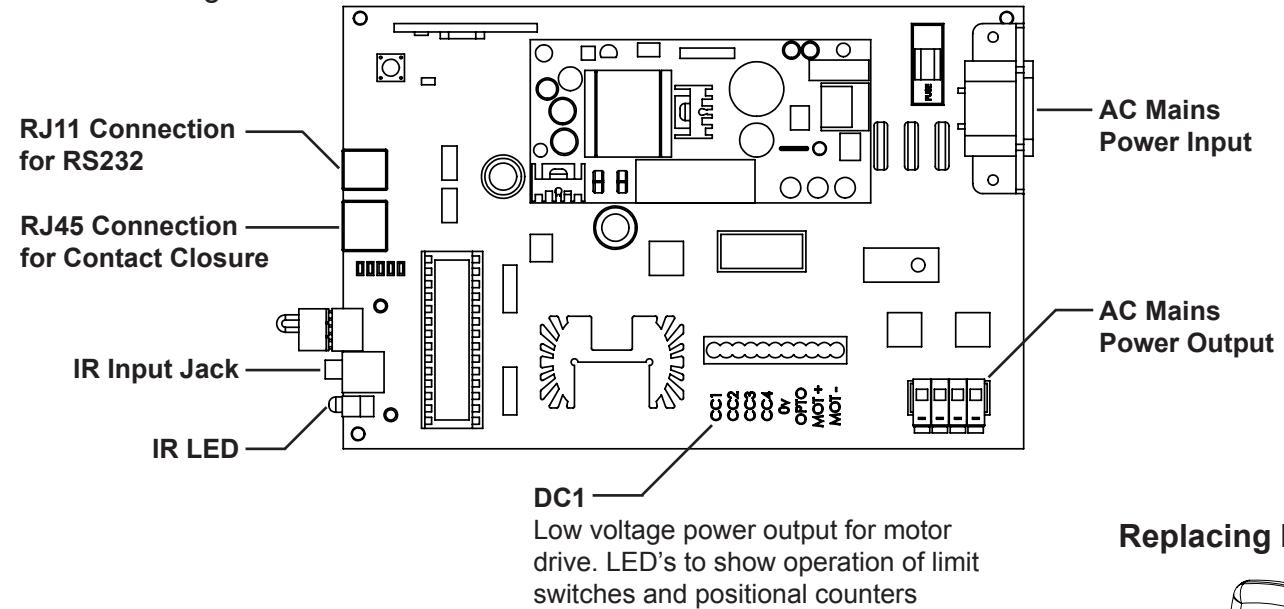

Installation: IR Control

In - Lowers the screen to stored position

Out - Raises the screen to stored position

Stop - Will stop the operation at any point

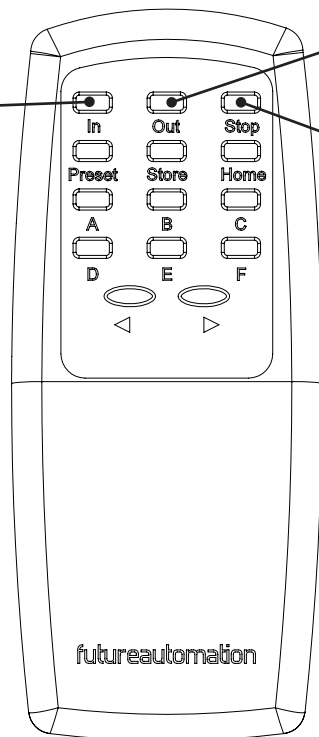

Replacing batteries

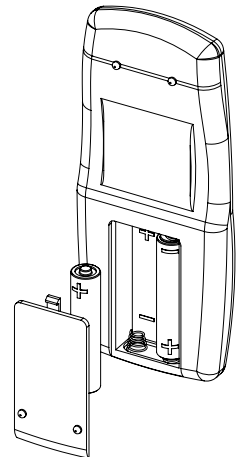

Future Automation IR Remote Controller needs x2 AAA batteries which are provided within the packaging

Storing positions

Press STORE + STORE + C to set height, current position will be stored after lift has fully lowered uninterrupted.

An interruption of this movement will cancel height setting.

Press STORE + STORE + B to clear set height.



Safety Note

When the mechanism is moving, if any button is pressed apart from those already assigned, the mechanism will stop immediately.

AL675 UDC1 Actuator Lift



RF Controls

The RF aerial is integrated into the circuit board.



If power is cut the mechanism can only go down.

RF Remote Control

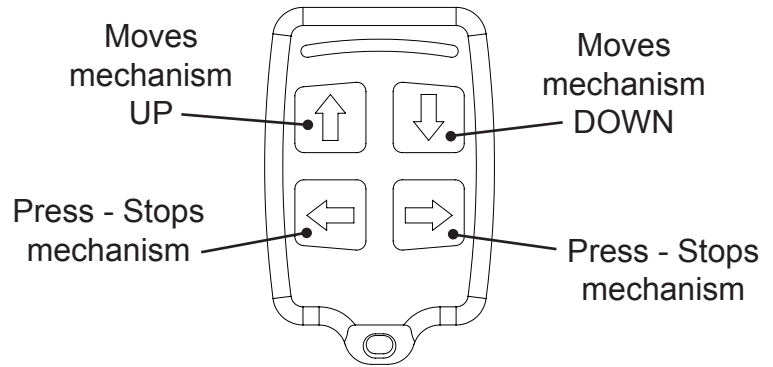

Storing positions

- Press limit button for under 5 seconds, nothing will happen.
- Press & hold for 5-10 secs (LED will flash) once released, current position will be stored after lift has fully lowered uninterrupted.
- Press & hold for 10 secs + (LED will stay on) once released, stored position is cleared.

Mechanism Output Power Supply

It is possible for the power to the screen to be switched by the control box. Use this connector to take power to the screen.

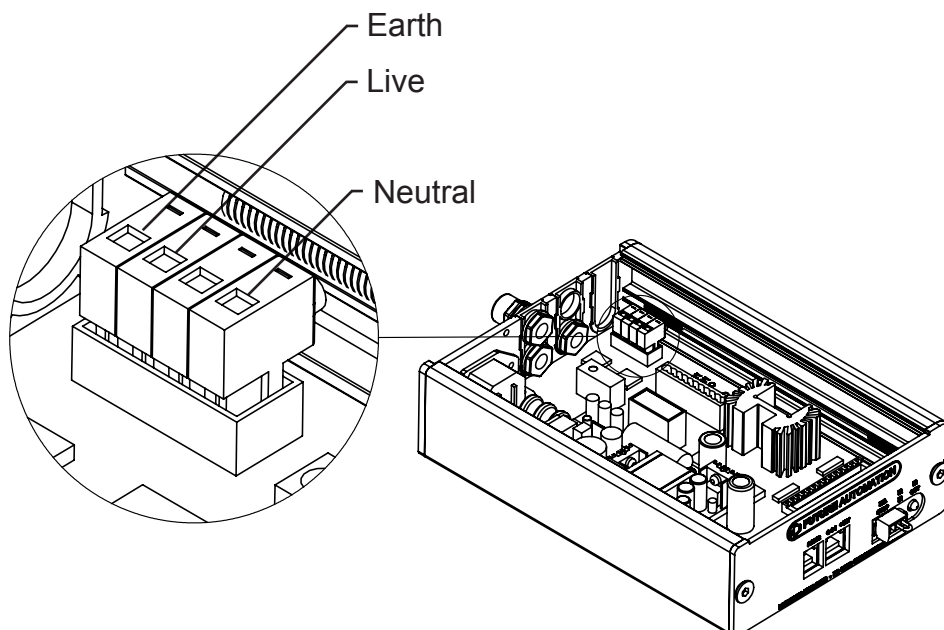

AL675 UDC1 Actuator Lift



RS232

- Use an RJ25 connector in the socket marked RS232 on the control box to operate using RS232

Details

Baud rate: 9600
 Stop bit: 1
 Parity: None
 Databits: 8

RJ25		9 PIN D
PIN 1: RX	TO	PIN 2: TX
PIN 6: TX	TO	PIN 3: RX
PIN 3: GROUND	TO	PIN 5: GROUND
PIN 4: GROUND	TO	PIN 5: GROUND



IMPORTANT

Ensure protocol is entered exactly as written.

Protocol	Action
fa_in Carriage Return (Enter ↵)	Device IN
fa_out Carriage Return (Enter ↵)	Device OUT
fa_stop Carriage Return (Enter ↵)	Device STOP (At any position)

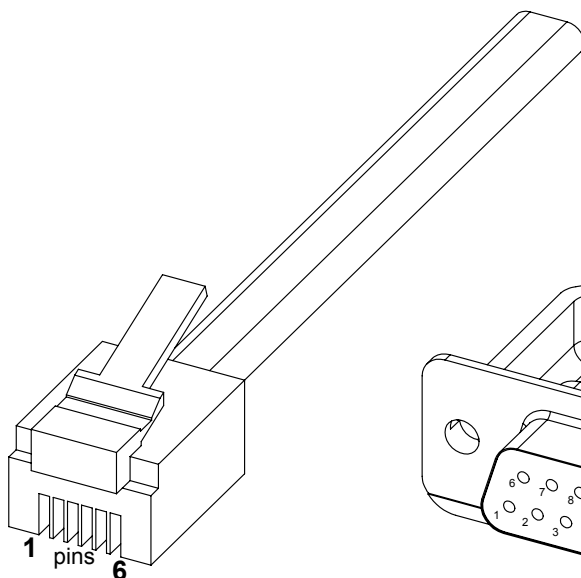

Pin 1: RX
Pin 6 : TX
Pin 3 & 4: GROUND

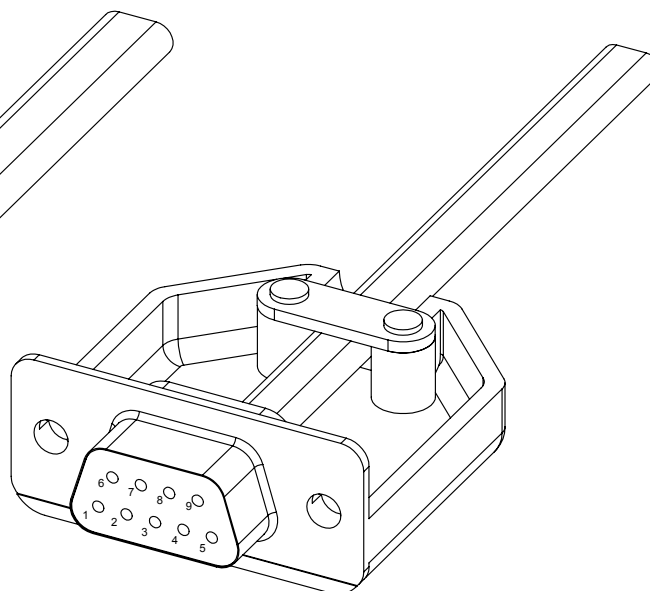

Pin 2: TX
Pin 3: RX
Pin 5: GROUND

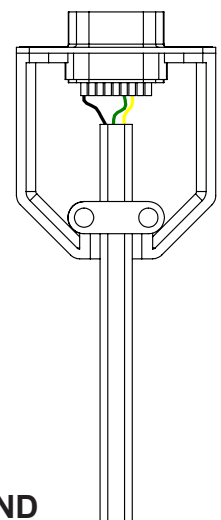

AL675 UDC1 Actuator Lift



Actuator lift 675 - Trouble shooting guide

Having problems? - Check the following:

1. Are all the connections correct?
2. Is the mechanism being operated correctly?

If the mechanism does not operate correctly, check the items listed in the table below. Should the problem persist, there may be a malfunction. If this is the case, disconnect the mains power immediately and contact your installer.

Symptom	Cause	Remedy	Page
Lift not working	IR receiver not plugged in	Connect IR receiver into 'IR IN' on interface	15
	Remote control or batteries faulty	Replace batteries or remote	15
	Control unit faulty	Contact manufacture	
Lid falls back when open	Incorrect cabinet dimensions	Check cabinet dimensions	13
Rubbing noise when opening	Push bars not at equal distance from flap	Re-position push bar	12
Unable to store positions	Remote control faulty or batteries	Replace batteries or remote	15
	Procedure not followed correctly	Refer to instructions	15



Future Automation

Unit 2 Kimpton Enterprise Park
Claggy Road
Kimpton
Hertfordshire
SG4 8HP
United Kingdom

Tel: +44 (0) 1438 833 577

Fax: +44 (0) 1438 833 565

Email: info@futureautomation.co.uk

www.futureautomation.co.uk