

PSE90

Motorised Articulated TV Wall Mount

Installation Instructions

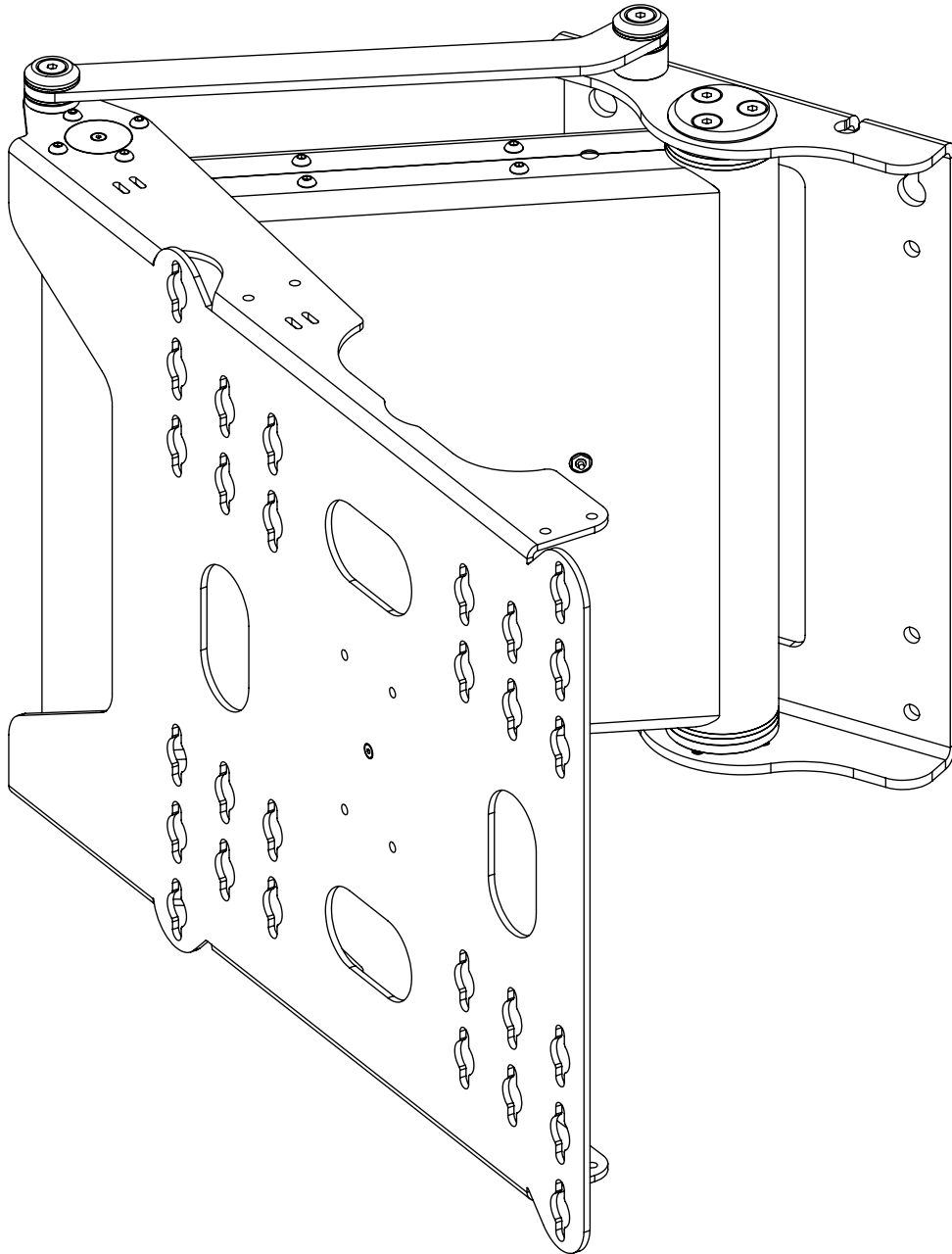

Safety Disclaimer

Product Safety Disclaimer - **IMPORTANT SAFETY INSTRUCTIONS BELOW**

WARNING: Failure to provide adequate structural strengthening, prior to installation can result in serious personal injury or damage to the equipment. It is the installer's responsibility to ensure the structure to which the component is affixed can support four times the weight of the component and any additional apparatus mounted to the component.

WARNING: Do not exceed the weight capacity for this product as listed below. This can result in serious personal injury or damage to the equipment. It is the installer's responsibility to ensure that the total combined weight of all attached components does not exceed that of the maximum figure stated.

WARNING: Risk of death or serious injury may occur when children climb on audio and/or video equipment or furniture. A remote control or toys placed on the furnishing may encourage a child to climb on the furnishing and as a result the furnishing may tip over on to the child.

WARNING: Risk of death or serious injury may occur. Relocating audio and/or video equipment to furniture not specifically designed to support audio and/or video equipment may result in death or serious injury due to the furnishing collapsing or over turning onto a child or adult.



Warning - Risk of Injury!



Only for use with screens weighing **132LBS (60KG) OR LESS**. Use with heavier screens/equipment may lead to instability causing tip over or failure resulting in death or serious injury.

Bracket Suitable for Residential and Commercial Use.

WARNING:

1. Keep all documentation/instructions after fitting.
2. Read all technical instructions fully before installation and use. It is the installer's responsibility to ensure that all documentation is passed on the end user and read fully before operation.
3. Do not use near water or outdoors unless the product has been specifically designed to do so.
4. Protect the any cables or cords being used near this bracket from being walked on or pinched to prevent damage and risk of injury.
5. Use this product only for its intended purpose as described in these instructions and only use attachments/accessories specified by the manufacturer.
6. Refer all servicing to qualified personnel. Servicing is required regularly on an annual basis.
7. Do not operate the product if it is damaged in any way, liquid has been spilled or objects have fallen into the apparatus, the apparatus has been exposed to rain or moisture, does not operate normally, or has been dropped. Contact the original installer/manufacturer to arrange repair or return.

WARNING - To reduce the risk of burns, fire, electric shock, or injury to persons:

1. Clean only with a dry cloth and always unplug any electrical items being used in conjunction with this product before cleaning.
-

Future Sound & Vision trading as Future Automation intend to make this and all documentation as accurate as possible. However, Future Automation makes no claim that the information contained herein covers all details, conditions or variations, nor does it provide for every possible contingency in connection with the installation or use of this product. The information contained in this document is subject to change without prior notice or obligation of any kind. Future Automation makes no representation of warranty, expressed or implied, regarding the information contained herein. Future Automation assumes no responsibility for accuracy, completeness or sufficiency of the information contained in this document.

Contents

Table Of Contents

Safety Disclaimer.....	2
Contents.....	3
Package Contents.....	4
Product Warranty.....	5
1 - Initial Testing.....	6
2 - Calculating Mounting Height.....	7
3 - Opening The Bracket Prior To Installation.....	8
4 - Wall Mounting the Bracket.....	9
5 - Cable Routing.....	10
6 - Screen Mounting.....	11
7 - Final Checks.....	12
8 - Presets and Storing Favourite Position.....	13
Mechanism Control.....	14
General Control.....	14
Infrared (IR) Operation.....	15
Contact Closure.....	16
RS232.....	17
Contact Information.....	18

Package Contents

Package Contents:

- 1 - PSE90 Mechanism
 - 1.1 - Screen Mount Plate
 - 1.2 - Wall Mount Plate
 - 1.3 - Mechanism Cover
 - 1.4 - Link Arm
- 2 - Infrared (IR) Remote Control

Items Not Shown On Page:

- 3 - PSE90 Control Board (Inside PSE90 Mechanism)
- 4 - PSE90 Accessory Pack
 - 4.1 - x2 AAA Batteries
 - 4.2 - Mains Power Lead
 - 4.3 - Infra-Ref Control Lead
 - 4.5 - CAT5 Lead with RJ45 Connector
 - 4.6 - Screen Fixings Pack (Multi-pack of Nuts, Bolts and Washers)

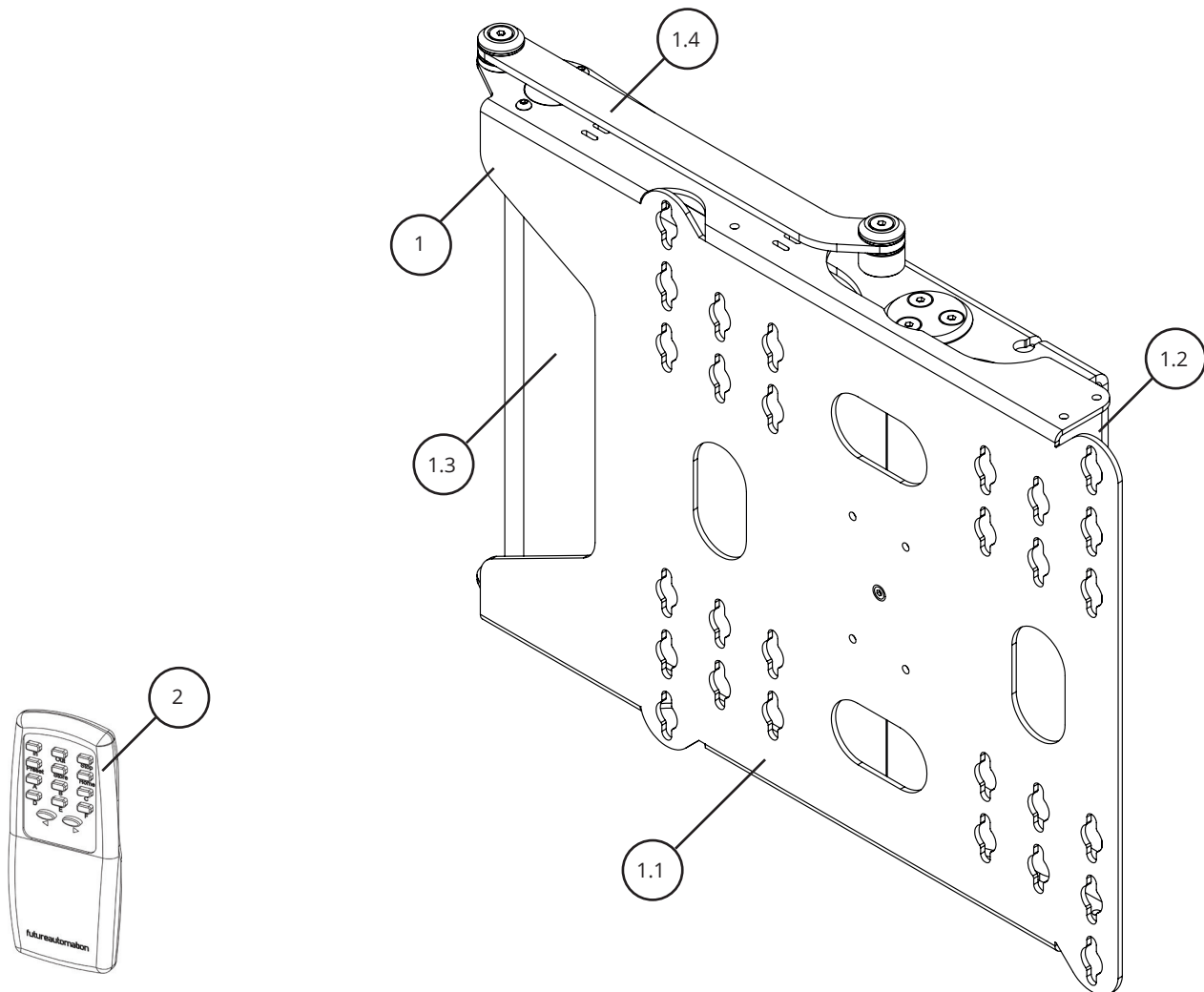

Product Warranty

Future Automation - Product Warranty Details

Your warranty covers the cost of labour and spare parts incurred by any defects in materials and workmanship under normal use during a **two year period from date of purchase**.

Under the warranty, we aim to either solve the issue remotely (via telephone or email support) or if the mechanism requires a part, arrange a visit to your premises by a Future Automation approved engineer or send replacement items where appropriate.

Support for any problems that are not hardware or software faults are excluded from the warranty entitlement.

Warranty repairs will be carried out as rapidly as possible, but subject to parts availability.

Some things are not covered under warranty, the following is excluded from warranty service:

- Malfunctioning caused by misuse or damage, accidental or otherwise, or service modification by persons not authorised by Future Automation, or the use of any non Future Automation supplied parts;
- Any electrical, or other environmental work external to your Future Automation mechanism including power cuts, surges or lightning strikes;
- Additional items not supplied by Future Automation although they may have been supplied together by the retailer;
- Any 3rd party software products controlling your mechanism;
- Any transfer of ownership. Warranty is provided only to the initial purchaser;
- Compensation for loss of use of the product, and consequential loss of any kind.

Any part of your system that needs to be replaced during a warranty repair becomes the property of Future Automation.

Customer Support - Contact Details

European Office

Address:

Unit 6-8
Brunel Road
Bedford
Bedfordshire
MK41 9TG

Phone: +44 (0) 1438 833577

Email: info@futureautomation.co.uk

Office Hours:

Mon - Fri 8:00 to 17:30 GMT
Saturday & Sunday - Closed

North American Office

Address:

Enterprise Park
127 Venture Drive
Dover
NH
03820

Phone: +1 (603) 742 9181

Email: info@futureautomation.net

Office Hours:

Mon - Fri 7:00 to 17:00 EST
Saturday & Sunday - Closed

Product/Installer Details - **To be Complete By Original Installer**

Installer Contact Details:

Contact Address:

Contact Phone: _____

Contact Email: _____

Original Installation Date: _____

Product Serial Number: _____

Installation Instructions

1 - Initial Testing

Before installation of the PSE90 mechanism, the following should be checked;

1. There is no damage to any part of the PSE90 mechanism, control board or wiring.
2. All internal and external mechanism wiring is secure.
3. The mechanism is in the fully CLOSED position.
4. The mechanism operates correctly. This can be tested by moving the mechanism between the CLOSED and OPEN positions using the IR Remote (Refer to Page 14 for Operating Instructions).



WARNING: THE PSE90 MECHANISM DOES NOT HAVE AN ANTI-JAM CAPABILITY. THE MOTOR DRIVE SYSTEM WILL CONTINUE TO MOVE UNTIL A LIMIT SWITCH IS CONTACTED. KEEP HANDS AND ANY OBJECTS CLEAR OF MECHANISM DURING OPERATION TO REDUCE RISK OF DAMAGE OR INJURY.



Fully Closed Position

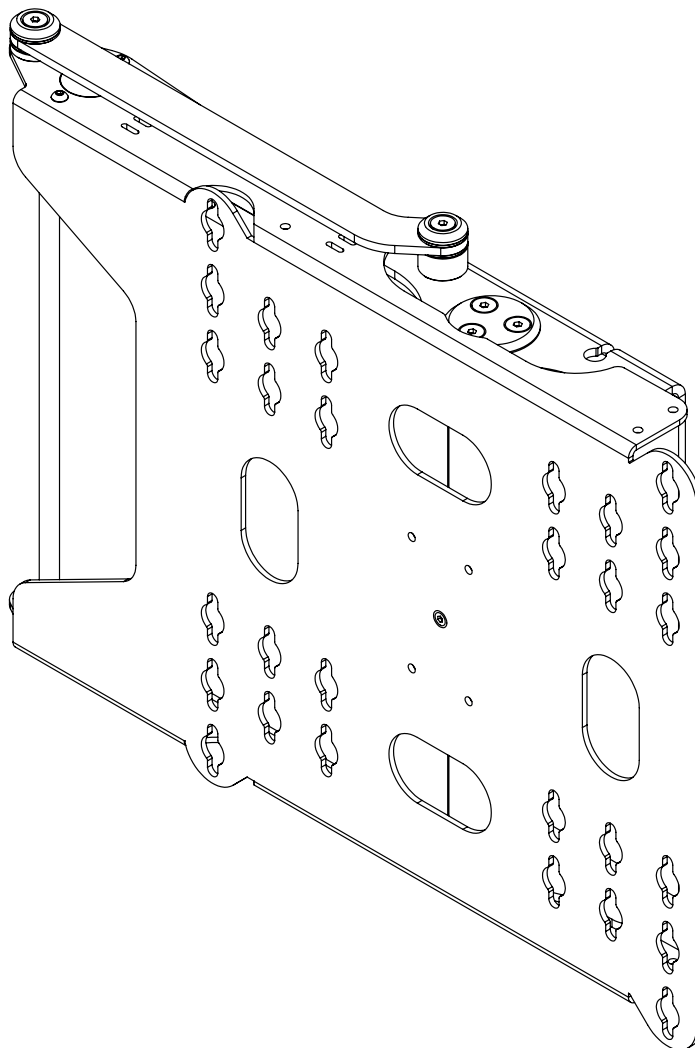

Installation Instructions

2 - Calculating Mounting Height

1. Carefully offer the PSE90 Mechanisms up to the back of the screen, lining up the screens VESA holes with the corresponding slots on the PSE90 Screen Mount Plate.
2. Measure from the top of the screen, down to the top mounting holes on the Wall plate (dimensions X as indicated below) to determine positioning of top the wall fixing holes.

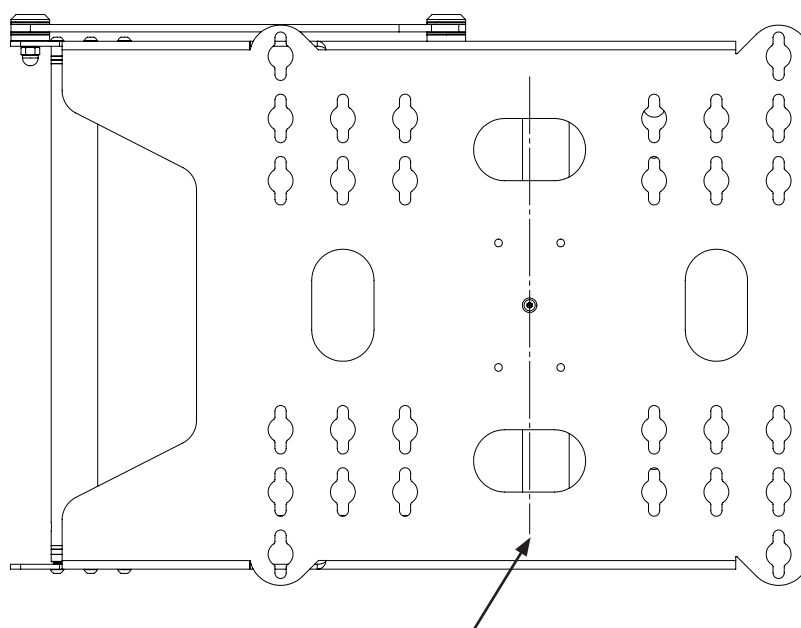
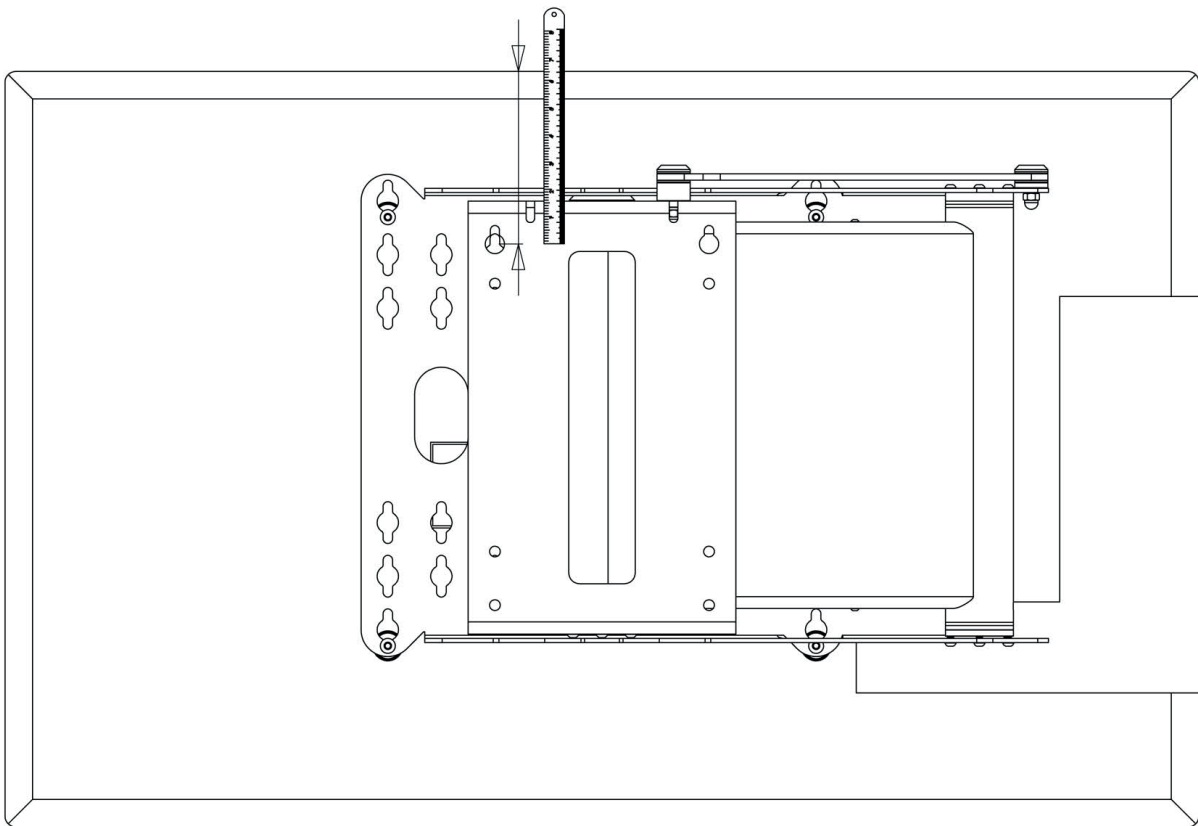

The centre of the screen's VESA pattern should sit on this centre line

Installation Instructions

3 - Opening The Bracket Prior To Installation

1. Hold the PSE90 by the wall plate, upside down (link arm underneath as shown below) on a soft, non-abrasive surface that is free from any obstructions.
2. Make sure the power is connected and press the HOME button on the remote control. This will open the PSE90 to the 45° position.
3. Once the bracket has stopped moving, remove the power and turn the PSE90 the correct way up.

Closed Position

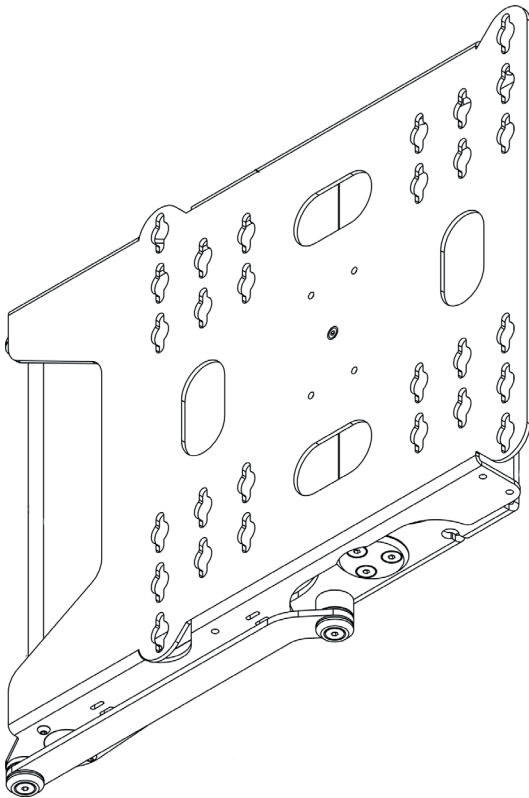

45° Position

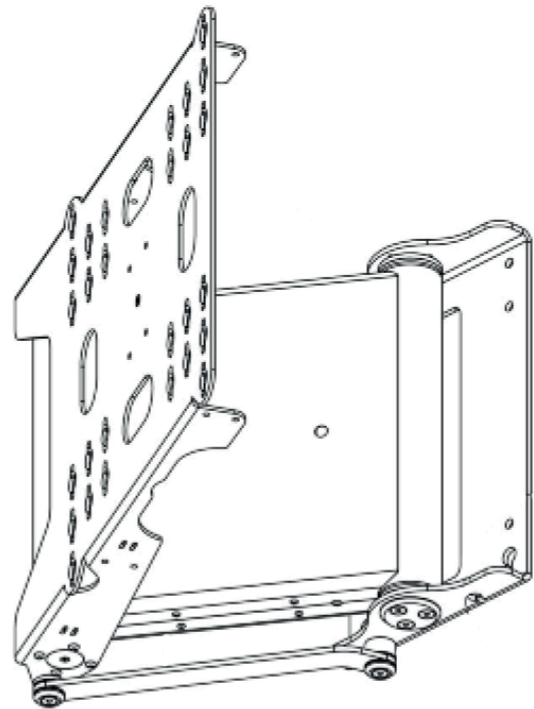

Installation Instructions

4 - Wall Mounting the Bracket

1. The top fixing holes for the PSE90 Wall Mount Plate should be located the distance of Dimension X (measured on page 7) down from the top of the desired screen position.
2. Fix the top 2 fixings into the wall, 200mm apart and symmetrically about the centre line of the wall plate.
3. Check these top 2 fixings are level, then hang the mechanisms onto the 2 fixings using the keyhole slots on the Wall Mount Plate.
4. Drill and screw the remaining 6 fixings in place using the holes in the Wall Mount Plate as a template.

NOTE: The wall fixing heads should NOT protrude more than 5.5mm from the Wall Mount Plate

NOTE: It is the installers responsibility to choose the appropriate fixings when attaching to the wall and to make sure the mechanism is secure and safe before operation.

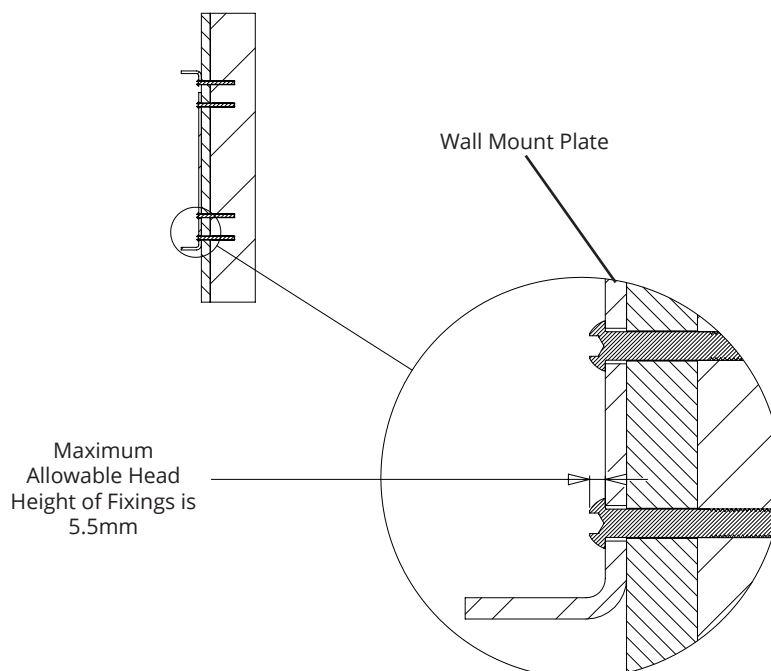
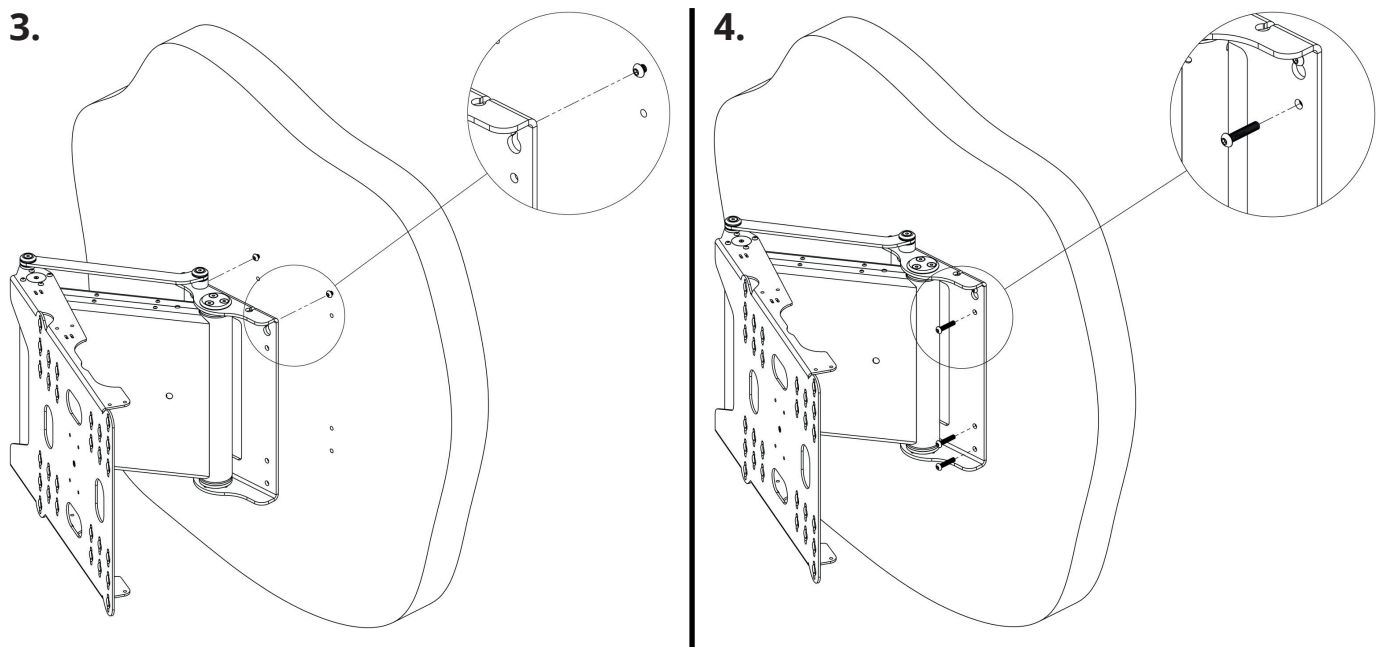

Installation Instructions

5 - Cable Routing

1. Once fitted to the wall, the PSE90 rear arm covers can be removed to allow easy cable routing. This is best done in the 90° OUT position. To open the bracket, plug in the mains power and press the OUT button on the IR Remote (Refer to Page 17 for Operating Instructions).
2. Once in the OUT position, remove the mains power and remove the 4 x M4 bolts that secure the rear arm cover to the PSE90.
3. Route TV power and signal cables through the mechanism as directed below. Ensure that enough slack is left for the movement of the mechanism to avoid putting stress on the cables. All cables should also be well secured and kept as low profile as possible.
4. Replace the rear arm cover by re-securing the 4 x M4 bolts removed in step 2.

2.

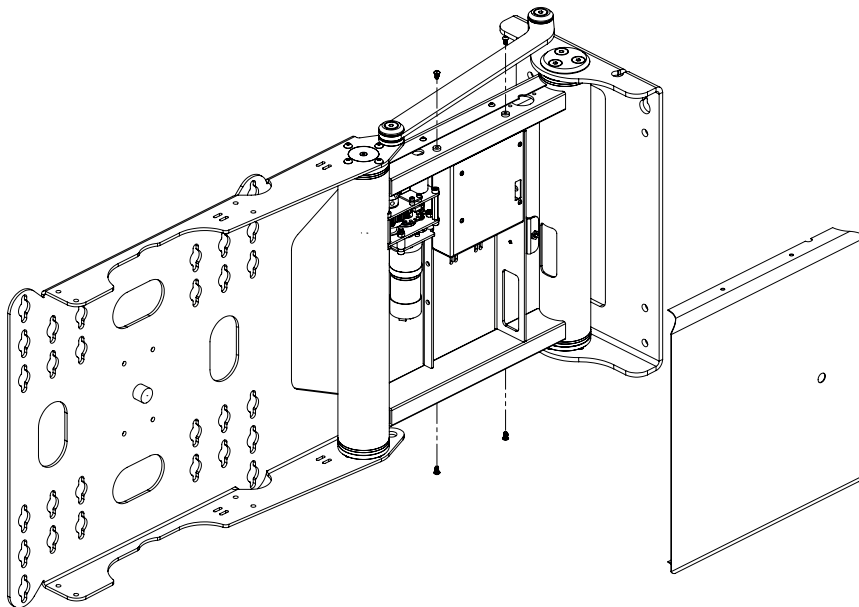

3.

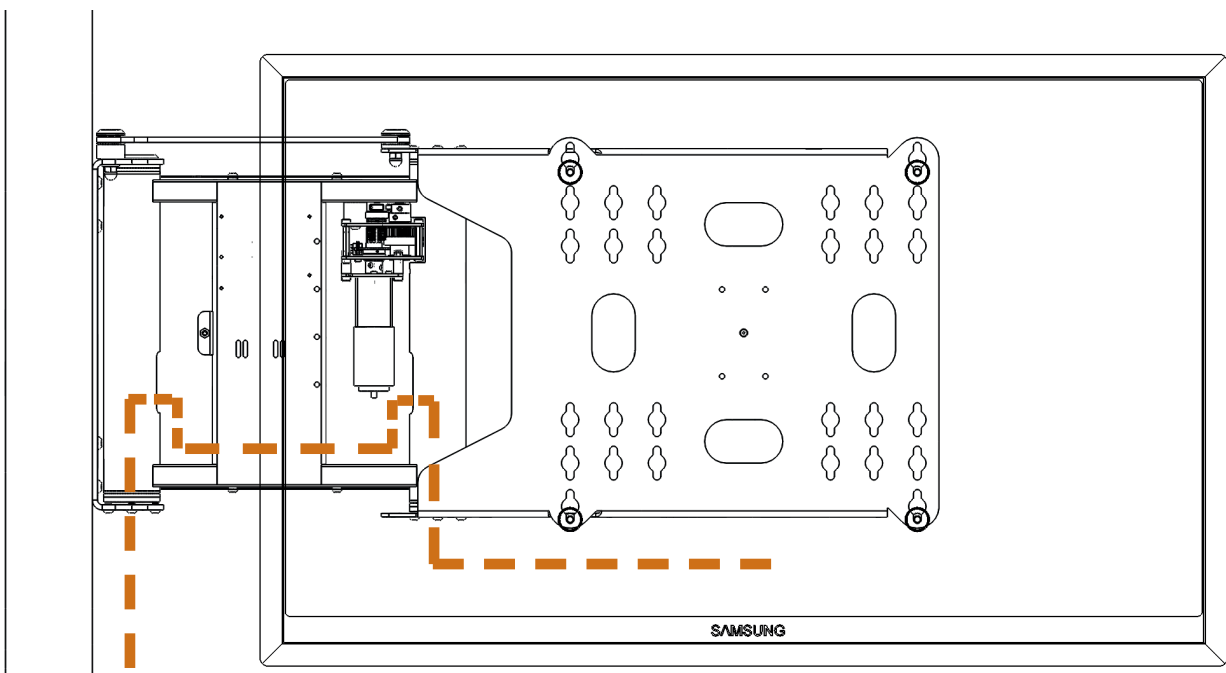

Installation Instructions

6 - Screen Mounting

1. Secure the Screen to the Screen Mount Plate using the bolts and washers provided in the Fixings Pack as shown below. If the screen has recessed mount holes or if you need to space the screen off for clearance, use the spacers provided in the Fixings Pack. This is best done in the 90° OUT position. To open the bracket, plug in the mains power and press the OUT button on the IR Remote (Refer to Page 17 for Operating Instructions).

1.

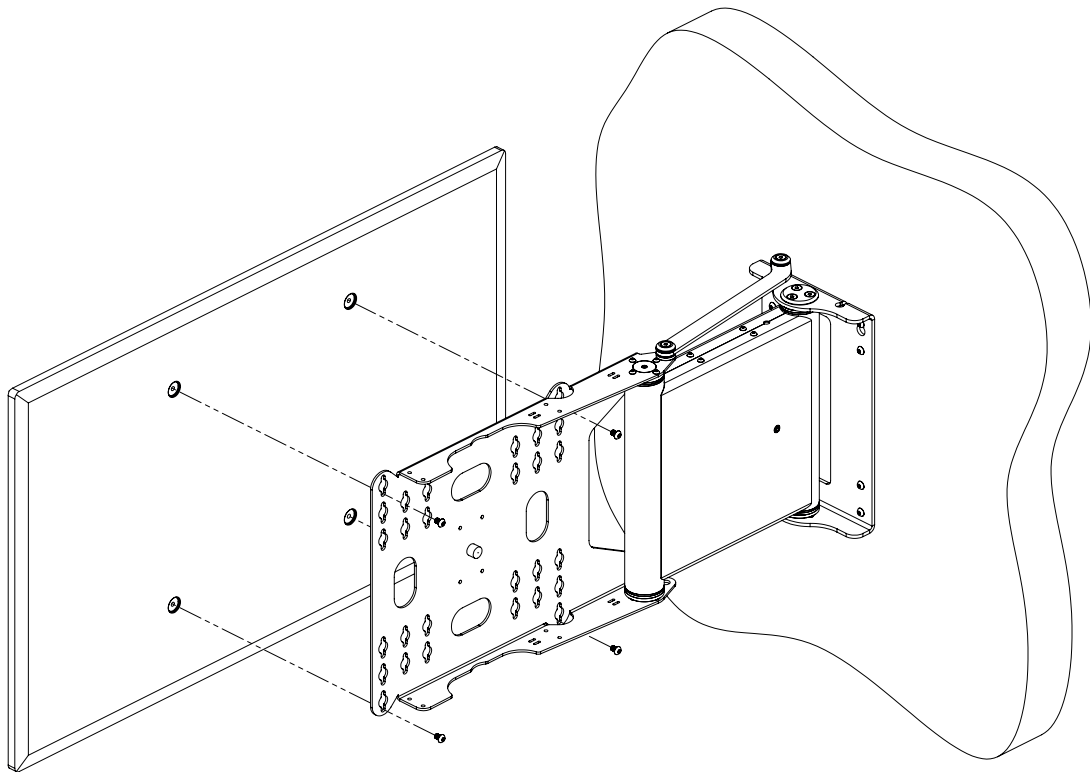

Installation Instructions

7 - Final Checks

1. Make sure that both rear arm covers are fully secured to the mechanism
2. Check that there are no obstructions in the mechanisms movement (e.g. Cables caught between the Screen Mount Plate and Rear Arm)
3. Check the mechanism square and level on the wall.

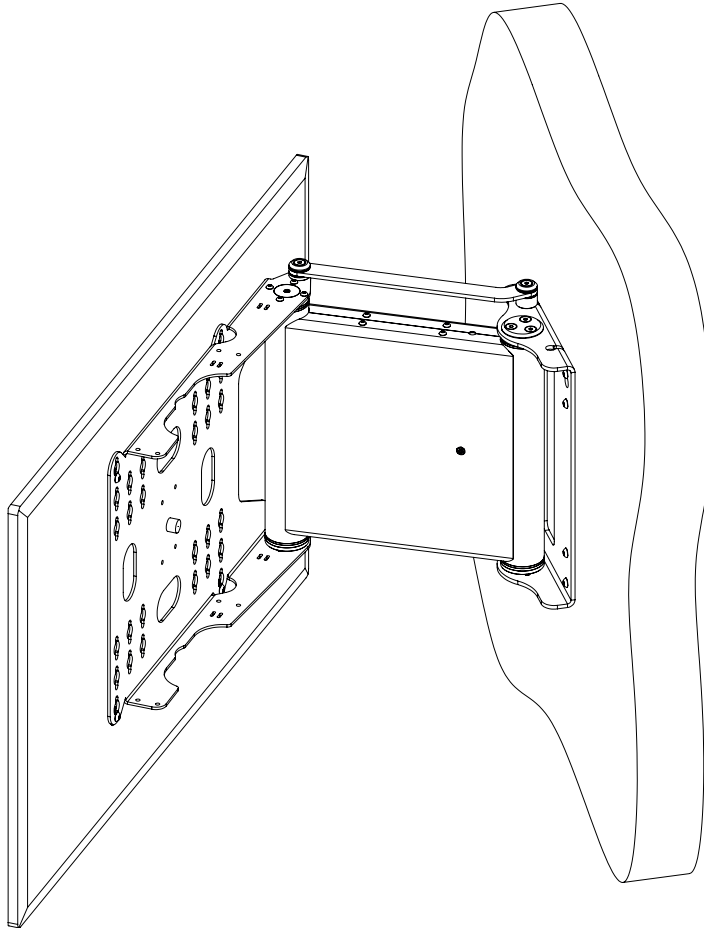

Installation Instructions

8 - Presets and Storing Favourite Position

1. The PSE90 has standard IN and OUT positions, as well as 7 programmable preset positions linked to the buttons shown below.
2. To overwrite any of the preset positions, use the IN, OUT and STOP buttons to take the mechanism to the desired position, then press the STORE button, followed by the desired preset button (HOME, PRESET or A-F). These buttons will need to be pressed within 2 seconds of each other.

NOTE: The preset positions will NOT be active until the mechanism has opened to its fully OUT position and then closed to the fully IN position.

NOTE: If the mechanism is moving and the power is cut, to revise ALL positions the mechanism needs to go back to the IN position, after which the previously stored programmed positions will be retained.

1. Bracket movement and preset options:

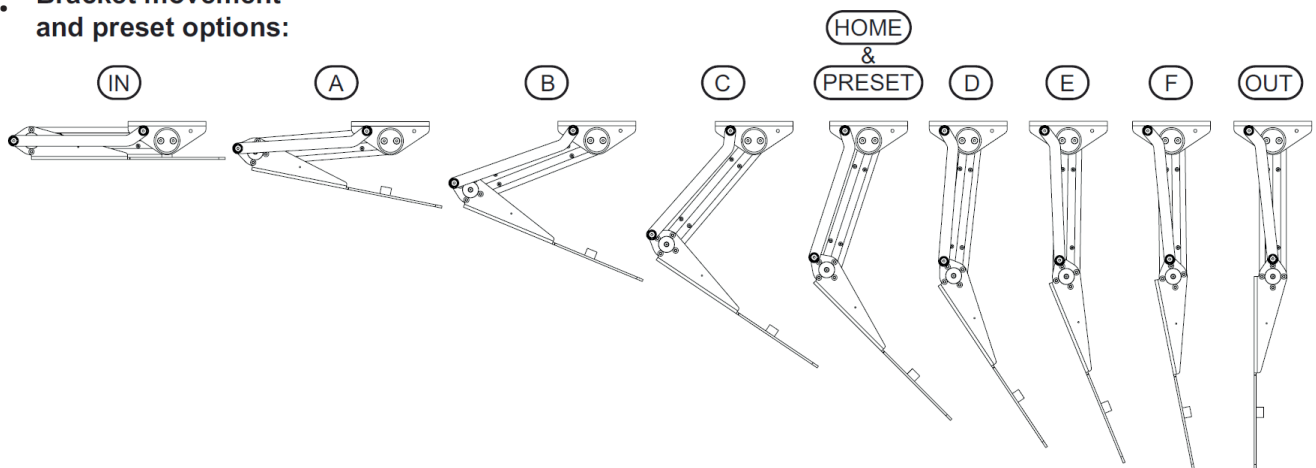

2. Storing favourite position

Store your favourite viewing position, which can be learned over and over again

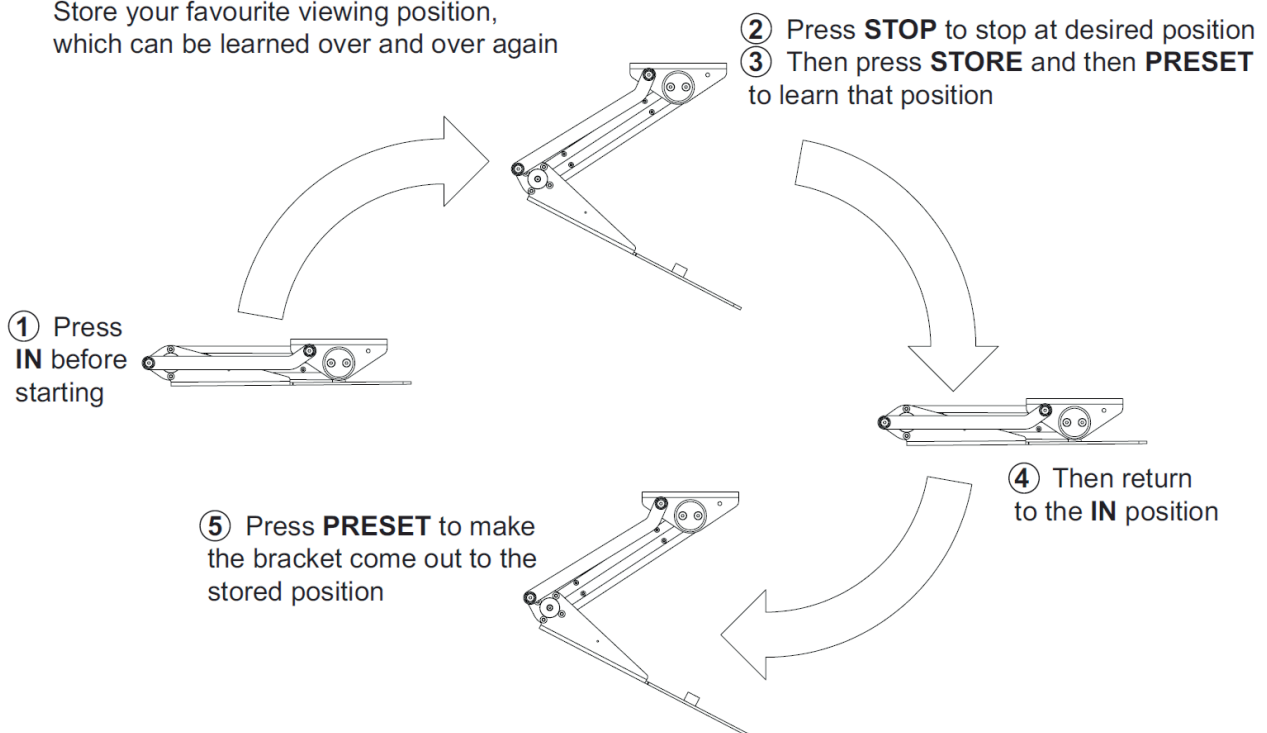

Mechanism Control

General Control

This mechanism has multiple standard control methods, each of which requires a different input method to the control box. For ease, the input sockets on the control board are labelled below. The PSE90 Control Board is located inside the rear arm of the PSE90 Mechanism.

Control Box Inputs and Connectors:

Mains Voltage Input (3 Pin IEC)

IR Input Jack (3.5mm)

Contact Closure (RJ45)

RS232 (RJ11/RJ25)

Emergency Stop Connector (3 Pin Phoenix)

Mechanism Emergency Stop Connector

This mechanism features an Emergency Stop Connector, which **MUST** be plugged into the control box in the connector labelled above for the mechanism to operate. If this connector is not plugged in, the Input Confirmation LED will be permanently lit. As per the red plastic tag attached to the Emergency Stop Connector (and shown below), the small loop of wire in this connector is designed to be replaced by a third party safety mechanism.



Replacing Mechanism Batteries

The standard Future Automation Infrared (IR) remote control required x2 AAA batteries to operate. These are provided with the mechanism in the Accessories Pack. These batteries can be replaced as the per the image below.

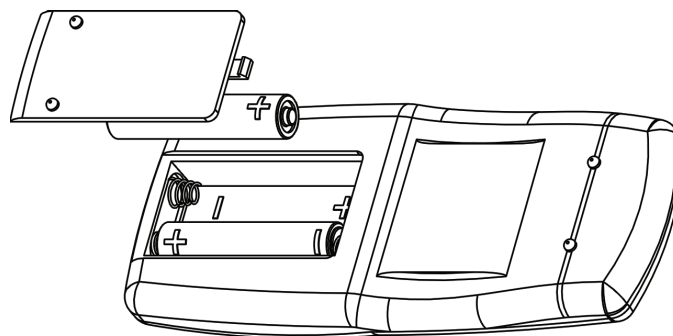

Mechanism Control

Infrared (IR) Operation

This Mechanism can be controlled via the supplied 14 button Infrared (IR) Remote Control, pair with the supplied Infrared (IR) lead and sensor.

The mechanism's functions can be controlled by plugging the Infrared (IR) lead and sensor into the 3.5mm IR Input Jack shown on the General Mechanism Control page.

Confirmation of Infrared (IR) input will be shown by a single flash of the large green LED located on the end of the control box.

As Infrared (IR) control works over line of site, the Infrared (IR) sensor must be directly viewable from what ever location the remote control is being used from.

Infrared (IR) Remote Control Button Layout

IN - Brings the mechanism into the wall.

PRESET - Brings the mechanism to mechanism to learnt position.

STORE - Programs current mechanism position to learn position.

OUT - Brings the mechanism out from the wall.

STOP - Will stop the operation of the mechanism at ANY position.

STORE + PRESET - Pressed with 1 second of each other stores **PRESET** position.

STORE + A-F - Pressed with 1 second of each other stores positions A-C.

A - F - Brings the mechanism to mechanism to learnt position.

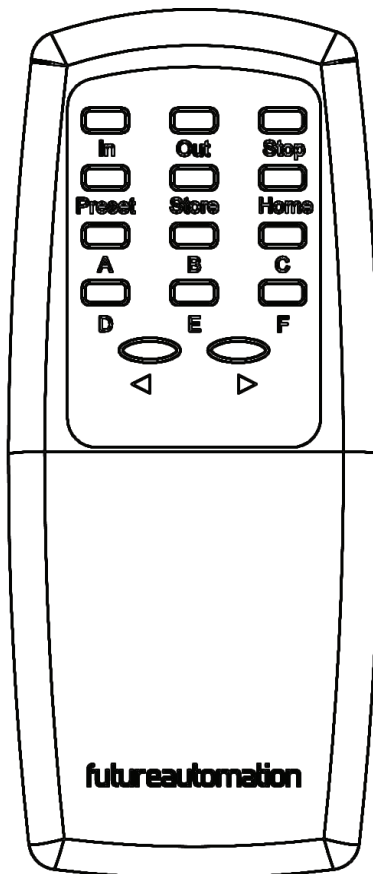

IMPORTANT

Only buttons indicated above are functional with the product. Any other button press will STOP the mechanism.

Mechanism Control

Contact Closure

This Mechanism can be controlled via Contact Closure, utilising an 8 Pin RJ45 Connector attached to a length of CAT5 (Type 568A or 568B) cable.

The mechanism's functions can be controlled by plugging this into the RJ45 port on the mechanism control board, then shorting pins 1-8 on this connector as shown in the Contact Closure Input Table below.

Confirmation of Contact Closure input will be shown by a single flash of the large green LED located on the end of the control box, as well as illumination of the corresponding Contact Closure LED on the printed circuit board as shown below.

RJ45 Pin Layout

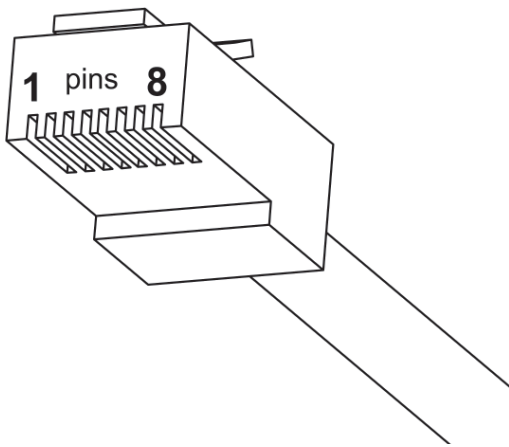

Contact Closure LED Layout

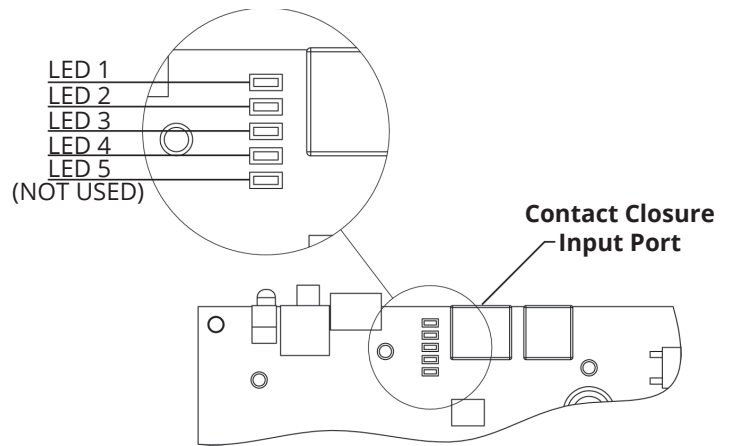

Contact Closure Input Table

PIN	DESCRIPTION	ACTION
1	12V SUPPLY	12V SUPPLY - CURRENT LIMITED
2	12V LATCH	WHEN 12V ATTACHED, DEVICE WILL GO OUT TO PRESET POSITION. WHEN 12V REMOVED, DEVICE WILL GO IN.
3	GROUND	GROUND
4		
5	DEVICE LATCH	SHORT TO GROUND (PIN 3), DEVICE WILL GO OUT TO PRESET POSITION, REMOVE SHORT DEVICE WILL GO IN.
6	DEVICE STOP	MOMENTARY SHORT TO GROUND (PIN 3), STOPS DEVICE IN CURRENT POSITION.
7	DEVICE OUT	MOMENTARY SHORT TO GROUND (PIN 3), MAKES DEVICE GO OUT.
8	DEVICE IN	MOMENTARY SHORT TO GROUND (PIN 3), MAKES DEVICE GO IN.

WIRE/CABLE TYPE		LED INDICATOR
568A	568B	
W G	W O	
G	O	
W O	W G	
B	B	
W B	W B	LED 4
O	G	LED 3
W BR	W BR	LED 2
BR	BR	LED 1

Mechanism Control

RS232

This Mechanism can be controlled via RS232, utilising a 6 Pin RJ11/RJ25 connector OR 9 Pin Serial connector attached to a length of 6 core cable.

The mechanism's functions can be controlled by plugging this into the RJ11/RJ25 port on the mechanism control box, then inputting the RS232 commands shown in the RS232 Input Table below.

Confirmation of Contact Closure input will be shown by a single flash of the large green LED located on the end of the control box.

RJ11/RJ25 Pin Layout

- PIN 1: RX**
- PIN 6: TX**
- PIN 3 & 4: GROUND**

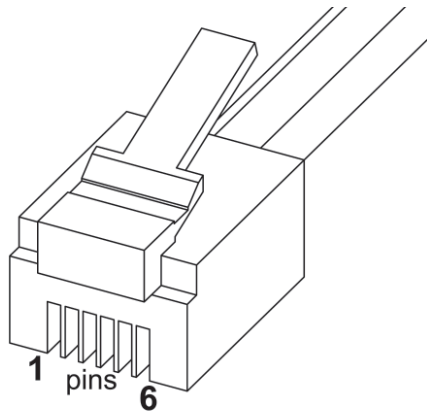

Serial Pin Layout

- PIN 2: RX**
- PIN 3: TX**
- PIN 5: GROUND**

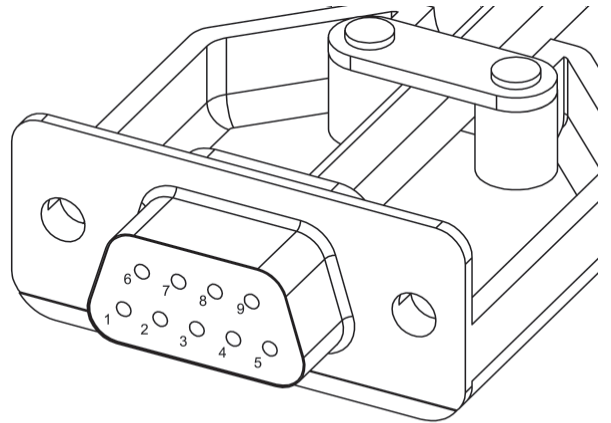

RS232 Programming Details

- Baud Rate: 9600
- Stop Bit: 1
- Parity: None
- Databits: 8

RJ11/RJ25	Func.	9 PIN Serial	Colour
PIN 1	TX-RX	PIN 2	Blue
PIN 3	GROUND	PIN 5	Green
PIN 4	GROUND	PIN 5	Red
PIN 6	RX-TX	PIN 3	White

RS232 Input Table

IMPORTANT - Ensure all protocols are entered exactly as written below, including Carriage Return (ENTER / ASCII 13)

COMMAND		ACTION
Step 1	Step 2	
fa_in ←↵		Device IN
fa_out ←↵		Device OUT
fa_stop ←↵		Device STOP
fa_store ←↵	fa_(preset, home,a-f) ←↵	Store memory position
fa_preset ←↵		Device to stored memory position

Contact Information



European Office

Address:

Unit 6-8
Brunel Road
Bedford
Bedfordshire
MK41 9TG

Phone: +44 (0) 1438 833577

Email: info@futureautomation.co.uk

Office Hours:

Mon - Fri 8:00 to 17:30 GMT
Saturday & Sunday - Closed

North American Office

Address:

Enterprise Park
127 Venture Drive
Dover
NH
03820

Phone: +1 (603) 742 9181

Email: info@futureautomation.net

Office Hours:

Mon - Fri 7:00 to 17:00 EST
Saturday & Sunday - Closed